

Camp Packing List

Ensure you bring items listed below, ✓ tick them as you pack.

Melbourne's known for having four seasons in one day, so check the forecast and pack suitably, as the weather can suddenly change from sunny to rain.



Sleeping

All guests need to bring their own.

- Pillow
- Sleeping bag
- Fitted sheet



Food

- Own lunch first day
- Re-fillable drink bottle



Shower Time

- Towel
- Toiletries (don't forget your toothbrush)



Clothing

- 1 set of pyjamas
- 1 set of clothing for each day (including socks/underwear)
- Rain coat
- Hat and sunscreen (slip, slop, slap)
- Sneakers (you'll be doing a lot of walking)
- Swimwear and an extra towel (if visiting Aquatic Centre)

! Do not bring aerosols or nut products.

Additional Items: _____

Carry-On Luggage Options

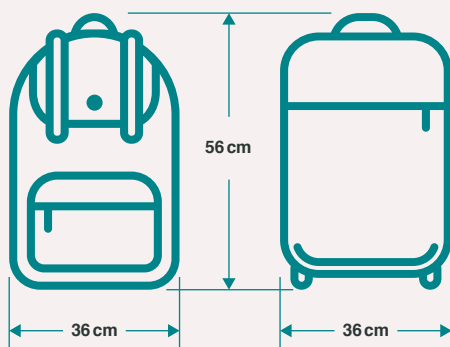

Backpacks: They are very easy for children to lift and move around between train/bus and camp.

Small case: A small case with wheels is a good alternative to the larger carry case.

! Weigh your bag. Maximum weight: 10 kg

Please keep in mind that each child needs to carry their own bag. As we have upstairs accommodation, this may include carrying luggage up two flights of stairs. A good rule is: if your child can't carry their bag, you may need to re-think what you have packed.

Remember to label each child's possessions.