

# Bible Play

## EASTER SUNDAY AND THE ROAD TO EMMAUS

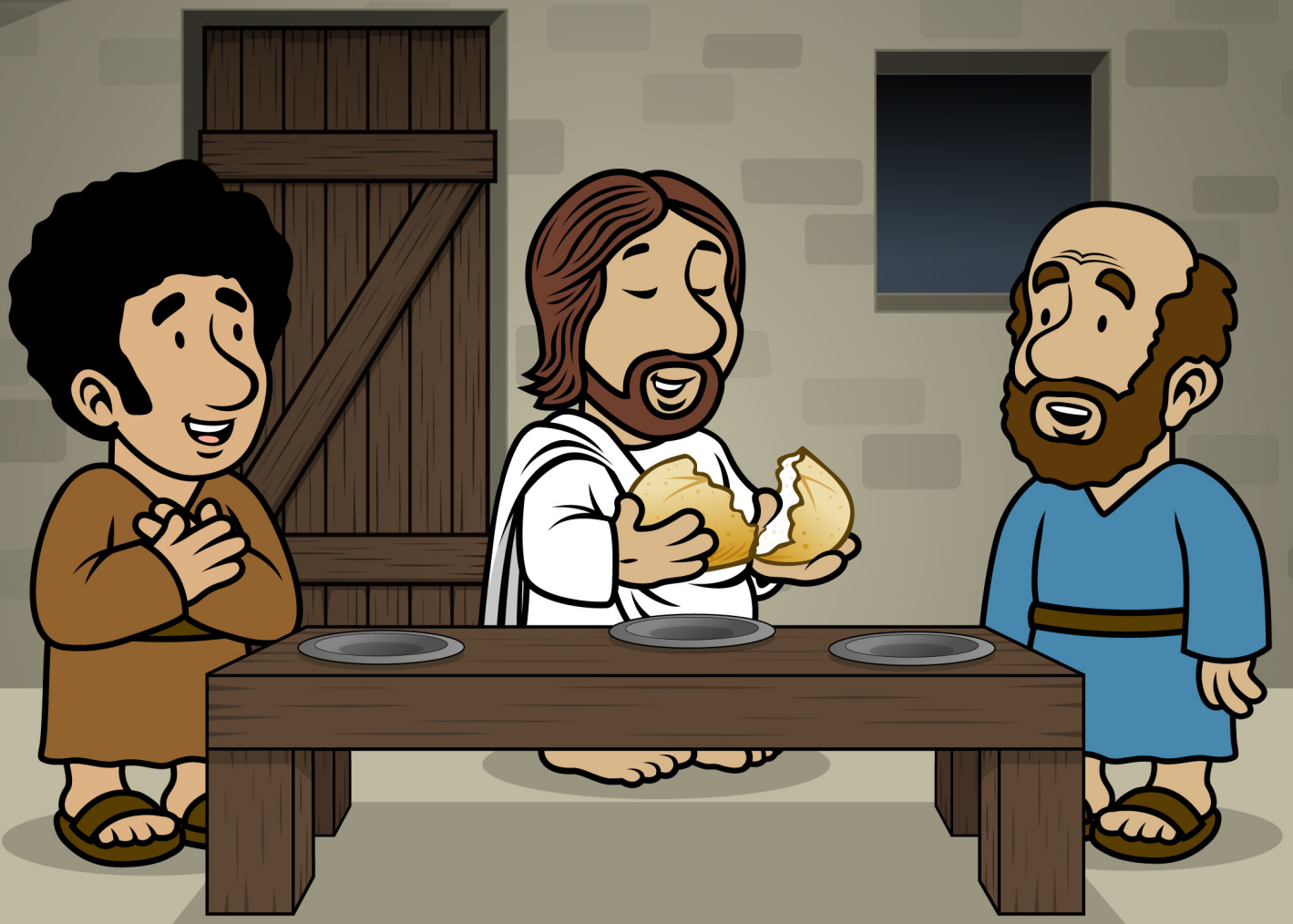

Gospel of Luke Story Set  
EASY VERSION

 Liturgy  
Help.



**This resource is designed to help children and students experience the story of Jesus' resurrection.**

This Bible Play story set is based on Luke's Gospel; other Easter story sets based on the gospels of John and Matthew are also available.

Bible Play story sets are suitable for families, classrooms, Children's Liturgy and general catechesis.

## EASTER SUNDAY: Gospel of Luke Story Set

The first half of Luke's account has many similarities with the other gospels, but in the second part of the story, Jesus first appears to the two disciples as they walk along the road to Emmaus.

### Luke 24:1-35 (Jerusalem Bible)

On the first day of the week, at the first sign of dawn, the women went to the tomb with the spices they had prepared. They found that the stone had been rolled away from the tomb, but on entering discovered that the body of the Lord Jesus was not there. As they stood there not knowing what to think, two men in brilliant clothes suddenly appeared at their side. Terrified, the women lowered their eyes. But the two men said to them, 'Why look among the dead for someone who is alive? He is not here; he has risen. Remember what he told you when he was still in Galilee: that the Son of Man had to be handed over into the power of sinful men and be crucified, and rise again on the third day?' And they remembered his words.

When the women returned from the tomb they told all this to the Eleven and to all the others. The women were Mary of Magdala, Joanna, and Mary the mother of James. The other women with them also told the apostles, but this story of theirs seemed pure nonsense, and they did not believe them.

Peter, however, went running to the tomb. He bent down and saw the binding cloths, but nothing else; he then went back home, amazed at what had happened.

Two of the disciples of Jesus were on their way to a village called Emmaus, seven miles from Jerusalem, and they were talking together about all that had happened. Now as they talked this over, Jesus himself came up and walked by their side; but something prevented them from recognising him. He said to them, 'What matters are you discussing as you walk along?' They stopped short, their faces downcast.

Then one of them, called Cleopas, answered him, 'You must be the only person staying in Jerusalem who does not know the things that have been happening there these last few days.' 'What things?' he asked. 'All about Jesus of Nazareth' they answered 'who proved he was a great prophet by the things he said and did in the sight of God and of the whole people; and how our chief priests and our leaders handed him over to be sentenced to death, and had him crucified. Our own hope had been that he would be the one to set Israel free. And this is not all: two whole days have gone by since it all happened; and some women from our group have astounded us: they went to the tomb in the early morning, and when they did not find the body, they came back to tell us they had seen a vision of angels who declared he was alive. Some of our friends went to the tomb and found everything exactly as the women had reported, but of him they saw nothing.'

Then he said to them, 'You foolish men! So slow to believe the full message of the prophets! Was it not ordained that the Christ should suffer and so enter into his glory?' Then, starting with Moses and going through all the prophets, he explained to them the passages throughout the scriptures that were about himself.

When they drew near to the village to which they were going, he made as if to go on; but they pressed him to stay with them. 'It is nearly evening' they said 'and the day is almost over.' So he went in to stay with them. Now while he was with them at table, he took the bread and said the blessing; then he broke it and handed it to them. And their eyes were opened and they recognised him; but he had vanished from their sight. Then they said to each other, 'Did not our hearts burn within us as he talked to us on the road and explained the scriptures to us?'

They set out that instant and returned to Jerusalem. There they found the Eleven assembled together with their companions, who said to them, 'Yes, it is true. The Lord has risen and has appeared to Simon.' Then they told their story of what had happened on the road and how they had recognised him at the breaking of bread.

The scriptural quotations are taken from the Jerusalem Bible, published and copyright 1966, 1967 and 1968 by Darton Longman and Todd Ltd and Doubleday & Co Inc, and used by permission of the publishers.

### CHARACTERS

Characters included in this set are:

- **Mary Magdalene**
- **Mary, mother of James**
- **Joanna**
- **Two Angels**
- **Peter**
- **Cleopas**
- **Disciple**
- **Jesus**

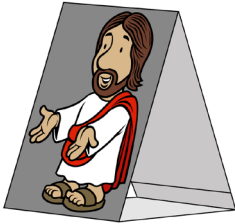

These character sheets have “easy cut-out” characters with different combinations of poses and expressions. They are much quicker and easier to produce than the standard versions.

We have also included black and white characters that the children might enjoy colouring in.



Mary Magdalene    Mother of James    Joanna    Angel    Angel

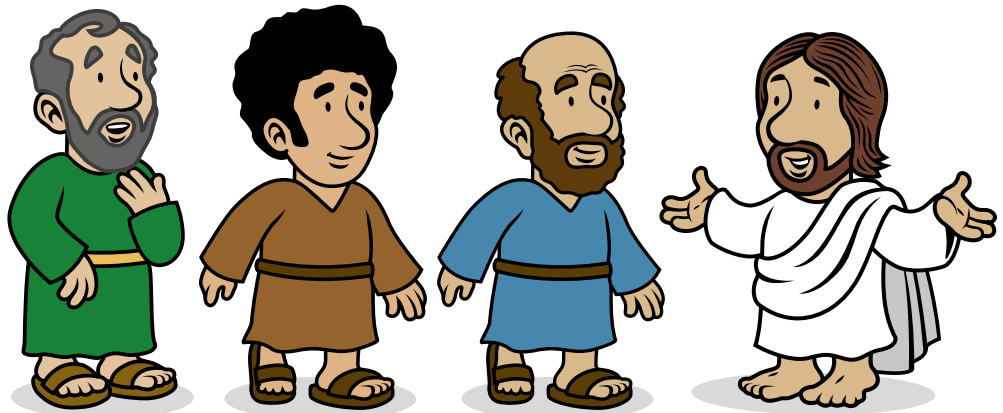

Peter    Cleopas    Disciple    Jesus

### PROPS

Props included in this set are:

- **Jesus' Tomb**
- **Peter's House\***
- **Trees, rocks and grasses**
- **Emmaus House**
- **Table**

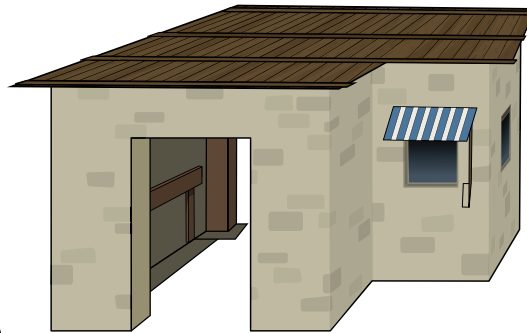

**Peter's House**

\* For simplicity, you could substitute this with a copy of the Emmaus House.

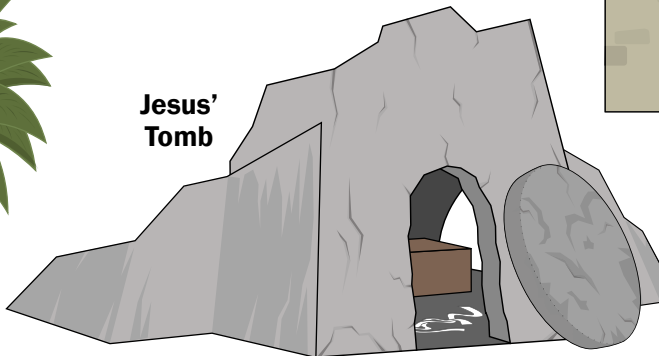

**Jesus' Tomb**

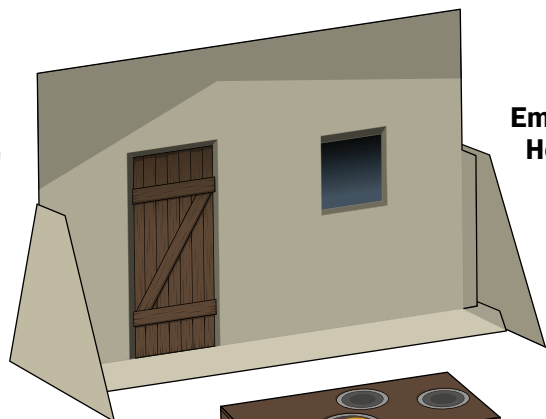

**Emmaus House**



**Trees**

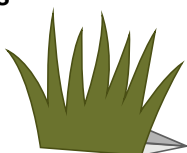

**Grasses**



**Rocks**



**Table**

The following script is based on the King James version of the Gospel of Luke, with some suggested stage directions to help get you started. You can adapt this script to suit your story-telling style.



STAGE LEFT

STAGE RIGHT

## SUGGESTED SCRIPT

**SET UP THE SCENE WITH JESUS' TOMB SET IN THE MIDDLE, PETER'S HOUSE SET TO STAGE RIGHT AND THE EMMAUS HOUSE SET TO STAGE LEFT. THE STONE SHOULD BE ROLLED BACK TO REVEAL THE TOMB ENTRANCE. DECORATE THE SPACES BETWEEN THE TOMB AND EMMAUS HOUSE WITH TREES AND GRASSES - THIS IS THE ROAD TO EMMAUS.**

**MARY MAGDALENE AND OTHER WOMEN ENTER FROM STAGE RIGHT AND STOP OUTSIDE THE TOMB ENTRANCE.**

It was very early on Sunday morning when Mary Magdalene, Mary the mother of James and Joanna went to visit Jesus' tomb. When they arrived, they saw that the large stone that sealed the tomb had been rolled away. They went inside the tomb...



**TURN AROUND JESUS' TOMB AND PLACE THE BURIAL PLATFORM IN FRONT OF THE TOMB WALL. PLACE THE WOMEN IN FRONT OF THE BURIAL PLATFORM.**

...and saw that Jesus was not there. As the women stood there wondering what had happened...

**PLACE TWO ANGELS ON THE STAGE, FACING THE WOMEN.**

...two men wearing shining garments appeared suddenly beside them. The women were frightened and they bowed their heads as the men asked them,



"Why do you seek the living amongst the dead? He is not here, for he has risen. Remember what he said to you in Galilee: that the Son of man must be delivered into the hands of sinful men, and be crucified, and on the third day rise again.

**REMOVE THE TWO ANGELS FROM THE STAGE**

Remembering what the men had told them, the women quickly left the tomb.

**TURN THE WOMEN SO THEY FACE STAGE RIGHT AND MOVE THEM AWAY FROM THE TOMB TOWARDS PETER'S HOUSE, STOPPING THEM OUTSIDE THE DOORWAY. PLACE PETER STANDING IN FRONT OF THE DOORWAY**



When they found the apostles, the women told them everything they had seen and heard. Most of the apostles did not believe their story, but Peter wanted to see for himself, and so he ran all the way to the tomb.

**MOVE PETER AND PLACE HIM OUTSIDE THE TOMB ENTRANCE.**

Looking in through the opening, Peter saw the strips of linen cloth lying on the ground, but nothing else. Then he returned home; amazed at what he'd seen.

**REMOVE PETER AND THE TOMB FROM THE STAGE. PLACE CLEOPAS AND THE OTHER DISCIPLE ON THE STAGE IN THEIR WALKING POSES, FACING THE EMMAUS HOUSE.**

Around this time there were two of Jesus' disciples travelling from Jerusalem to a village called Emmaus. As they walked, they spoke of everything that had just happened in Jerusalem over the last few days, when suddenly...

**PLACE JESUS IN WALKING POSE ALONGSIDE THE DISCIPLES.**

...Jesus appeared walking along-side them. He said,

'What matters are you discussing as you walk along?'

Something was preventing the disciples from recognising Jesus. They stopped for a moment, looking sad and dejected, and the disciple called Cleopas said,

'You must be the only person staying in Jerusalem who does not know the things that have been happening there these last few days.'

'What things?' Jesus asked.

They replied,

'All about Jesus of Nazareth who proved he was a great prophet by the things he said and did in the sight of God and all His people. Our chief priests and leaders handed him over to be sentenced to death, and had him crucified.

We had hoped that he would be the one to set Israel free.

But then, two days later some women from our group went to the tomb in the early morning and did not find the body. They came back to tell us they had seen a vision of angels who declared he was alive! Some of our friends went to the tomb and found everything exactly as the women had reported, but they did not see our Lord.'

Then Jesus said to them,

'You foolish men! So slow to believe all that the prophets have spoken! Wasn't it foretold that the Christ should suffer, before entering into his glory?'



And then, starting with the writings of Moses and all the prophets, Jesus began explaining all the passages in the scriptures that were about himself.

**MOVE JESUS AND THE DISCIPLES TOWARDS THE EMMAUS HOUSE AND STOP THEM JUST OUTSIDE.**

As they neared the village of Emmaus, Jesus looked to continue on his journey, so the two disciples invited Jesus to stay with them. They said,

‘It is growing dark as the day nears its end.’

And so Jesus agreed to stay with them for the night.

**FLIP THE EMMAUS HOUSE SO WE SEE THE INSIDE WALL. PLACE THE TABLE IN FRONT OF THE WALL, AND POSITION JESUS IN THE MIDDLE AND THE DISCIPLES AT EACH END OF THE TABLE.**

During the evening they gathered together to share a meal. Jesus took the bread and blessed it, then he broke the bread and gave it to each of the disciples. Suddenly, their eyes were opened and they recognised Jesus! But at that moment, Jesus disappeared from their sight. The men said to each other,

‘Didn’t our hearts burn within us as he explained the scriptures to us?’

And at that late hour they hurried back to Jerusalem, where they found the apostles assembled together. They said,

‘It is true! The Lord has risen!’

And they told their story of what had happened along the road to Emmaus and how they had recognised him at the breaking of bread.

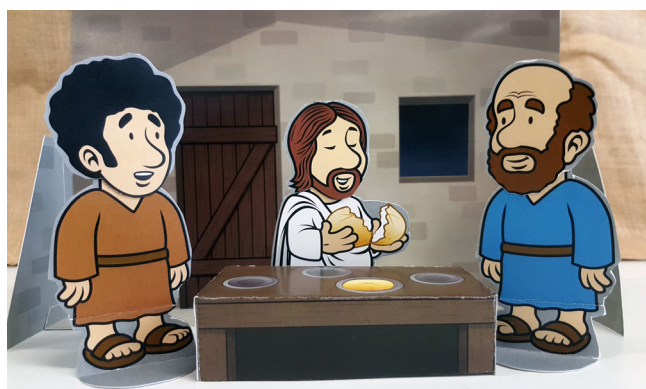

MARY  
MAGDALENE



MARY,  
MOTHER  
OF JAMES



JOANNA



PETER

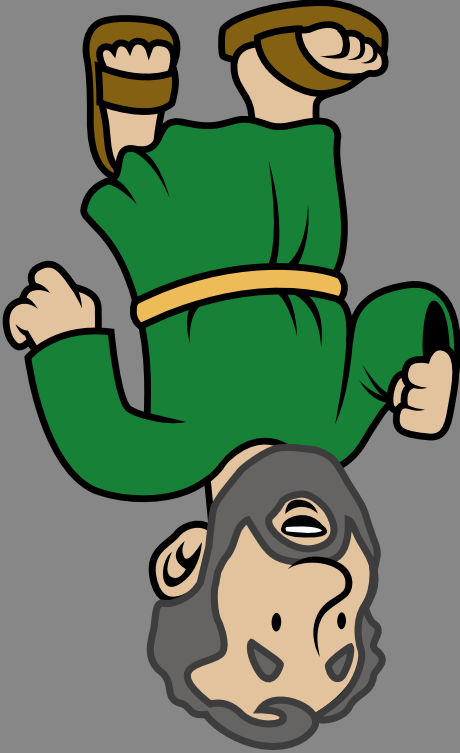

CLEOPAS



DISCIPLE

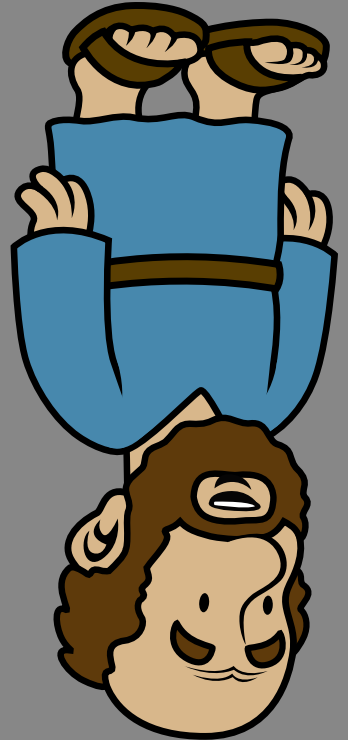



## CHARACTERS

RESURRECTED  
JESUS



ANGEL 1

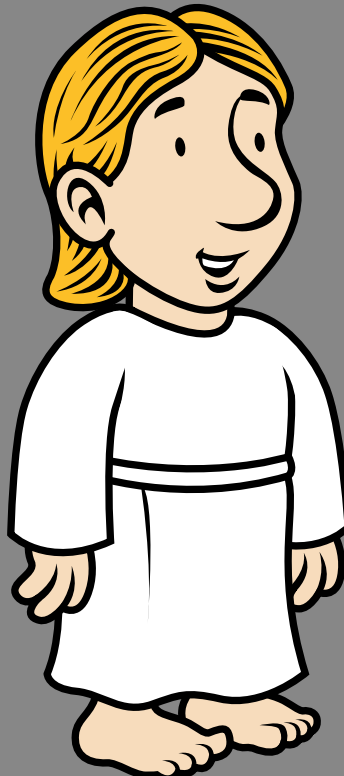
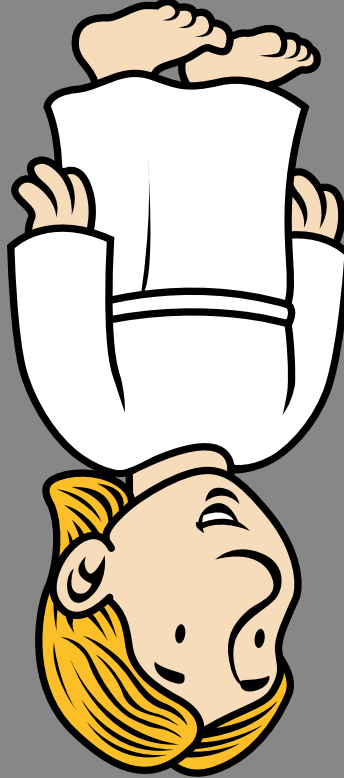

ANGEL 2

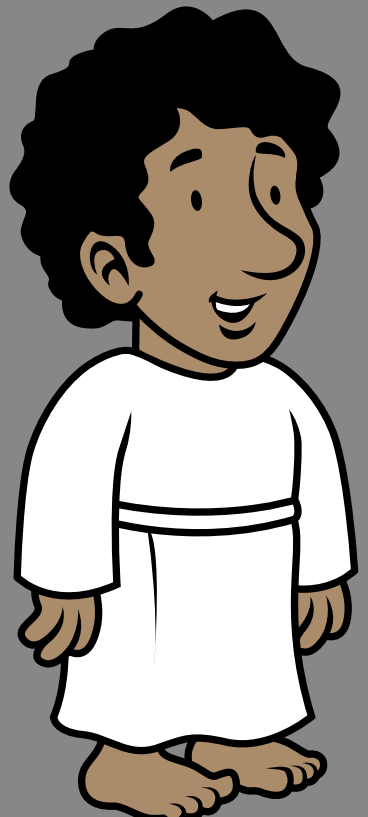

MARY  
MAGDALENE



MARY,  
MOTHER  
OF JAMES



JOANNA

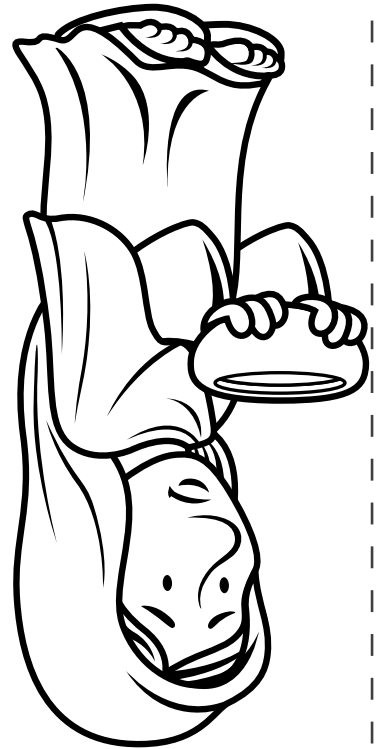

PETER

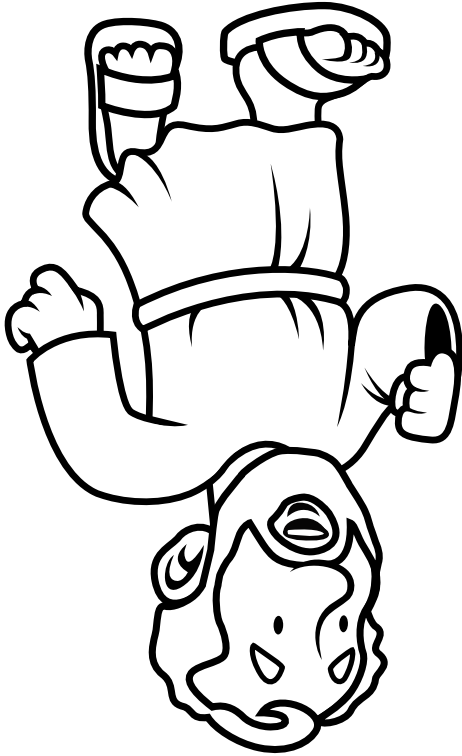

CLEOPAS

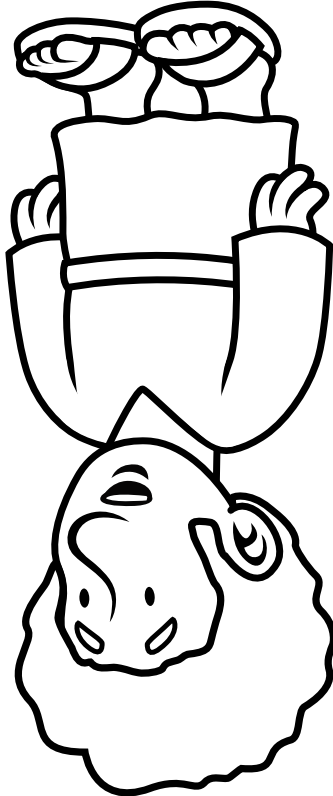

DISCIPLE

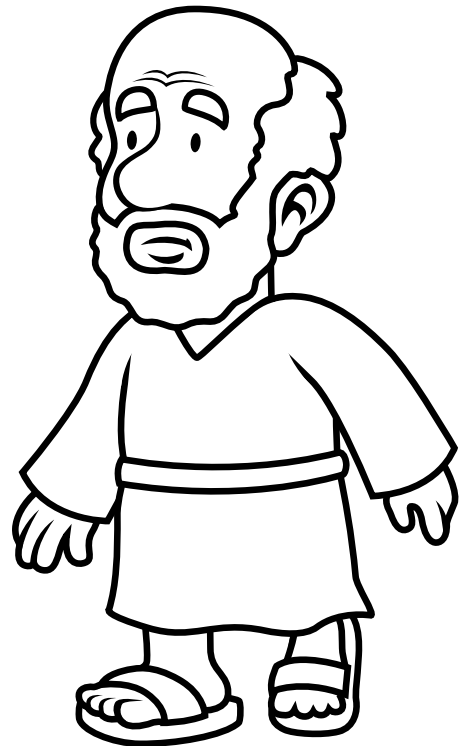
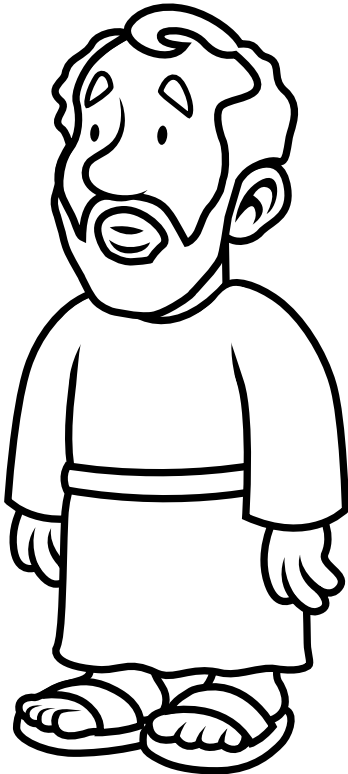
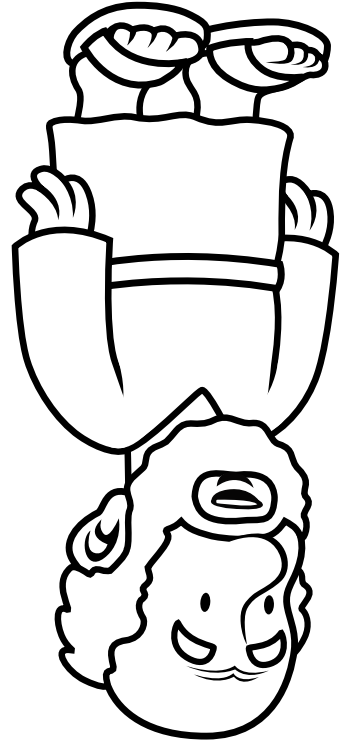

RESURRECTED  
JESUS

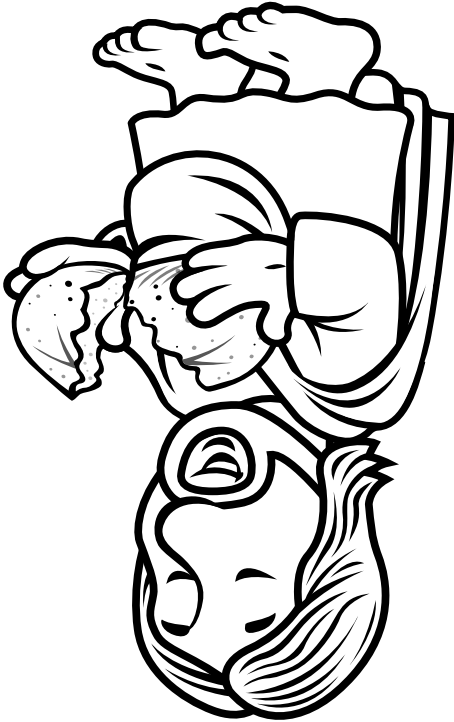

ANGEL 1

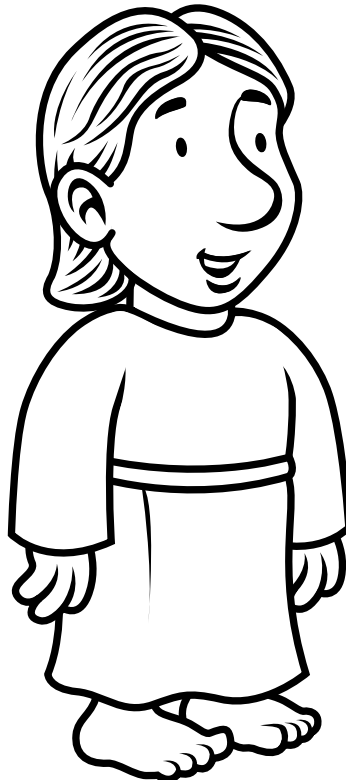
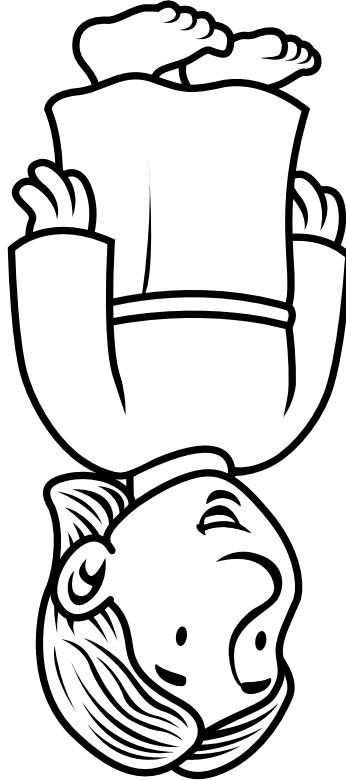

ANGEL 2

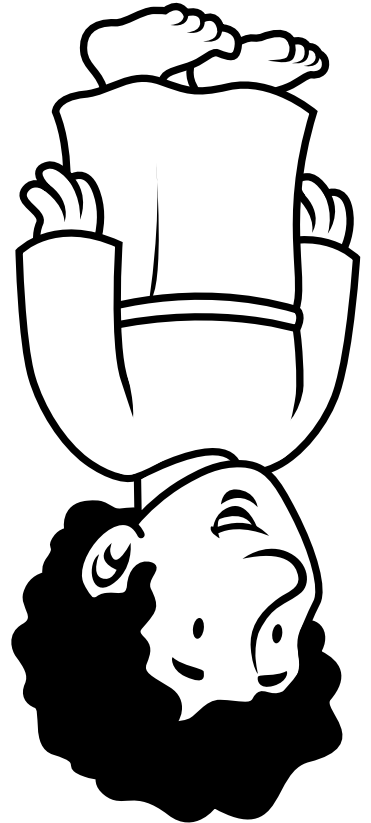

The **Bible Play** characters are designed to be printed onto standard office paper. For a more durable finish they can also be printed onto heavier card stocks – if suitable for your printer.

**STEP 1:** Print the character sheets onto paper or card stock. If scaling down the prints to better suit your printer's capabilities, be sure to scale down all the pages by the same amount (eg. 95%).

**STEP 2:** Cut out the character along the dashed lines.

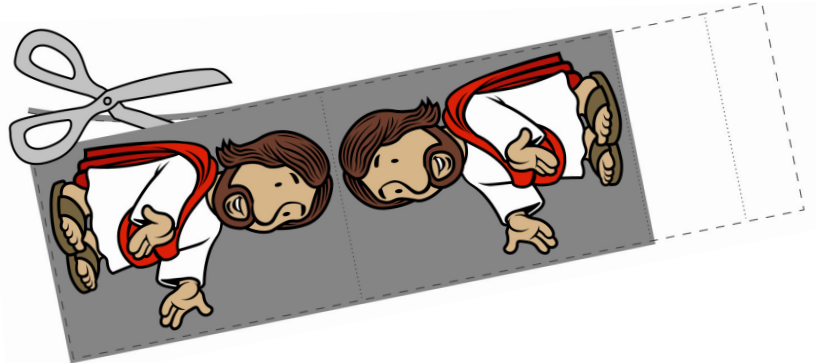

**STEP 3:** Fold along the fine dotted lines,

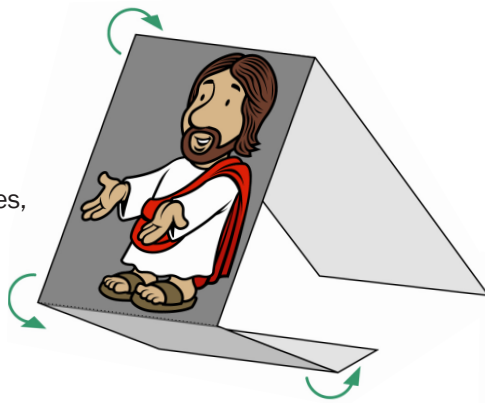

**STEP 4:** Apply glue to front of the small upper-tab.

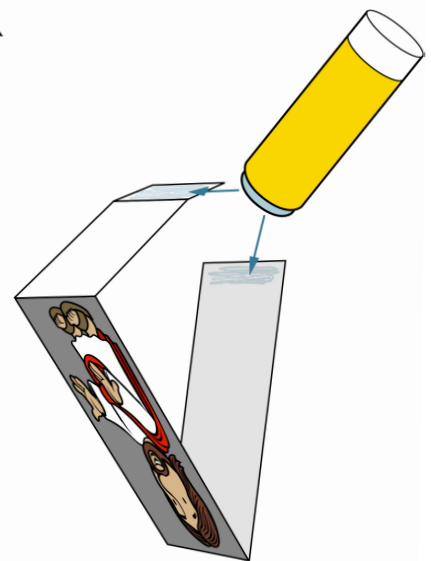

**STEP 5:** Bring the ends together and press firmly.

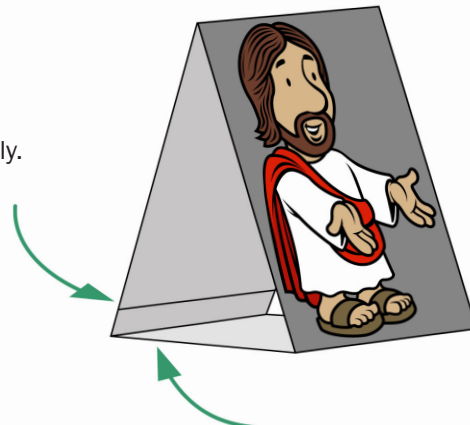

# JESUS' TOMB: FRONT

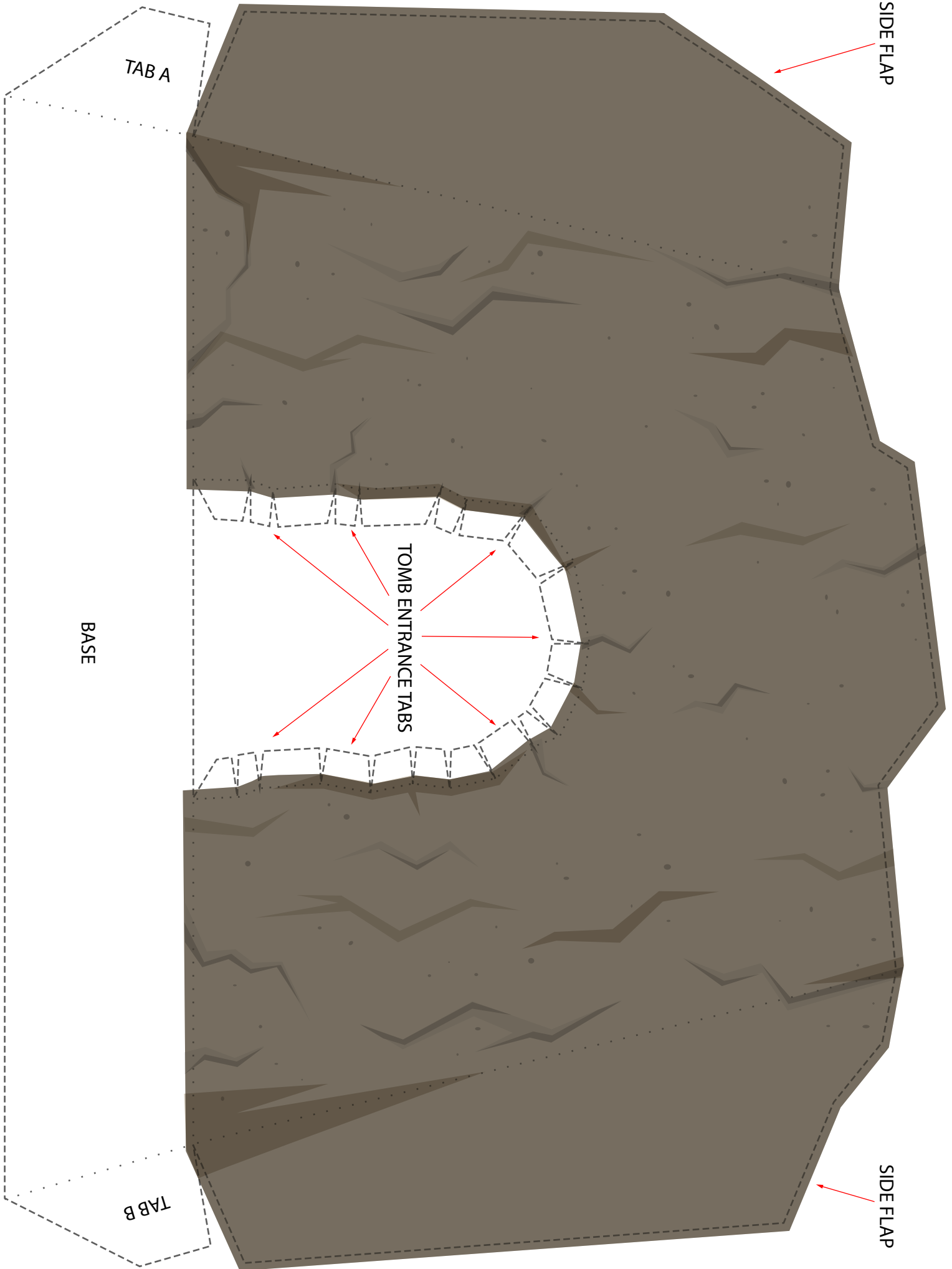

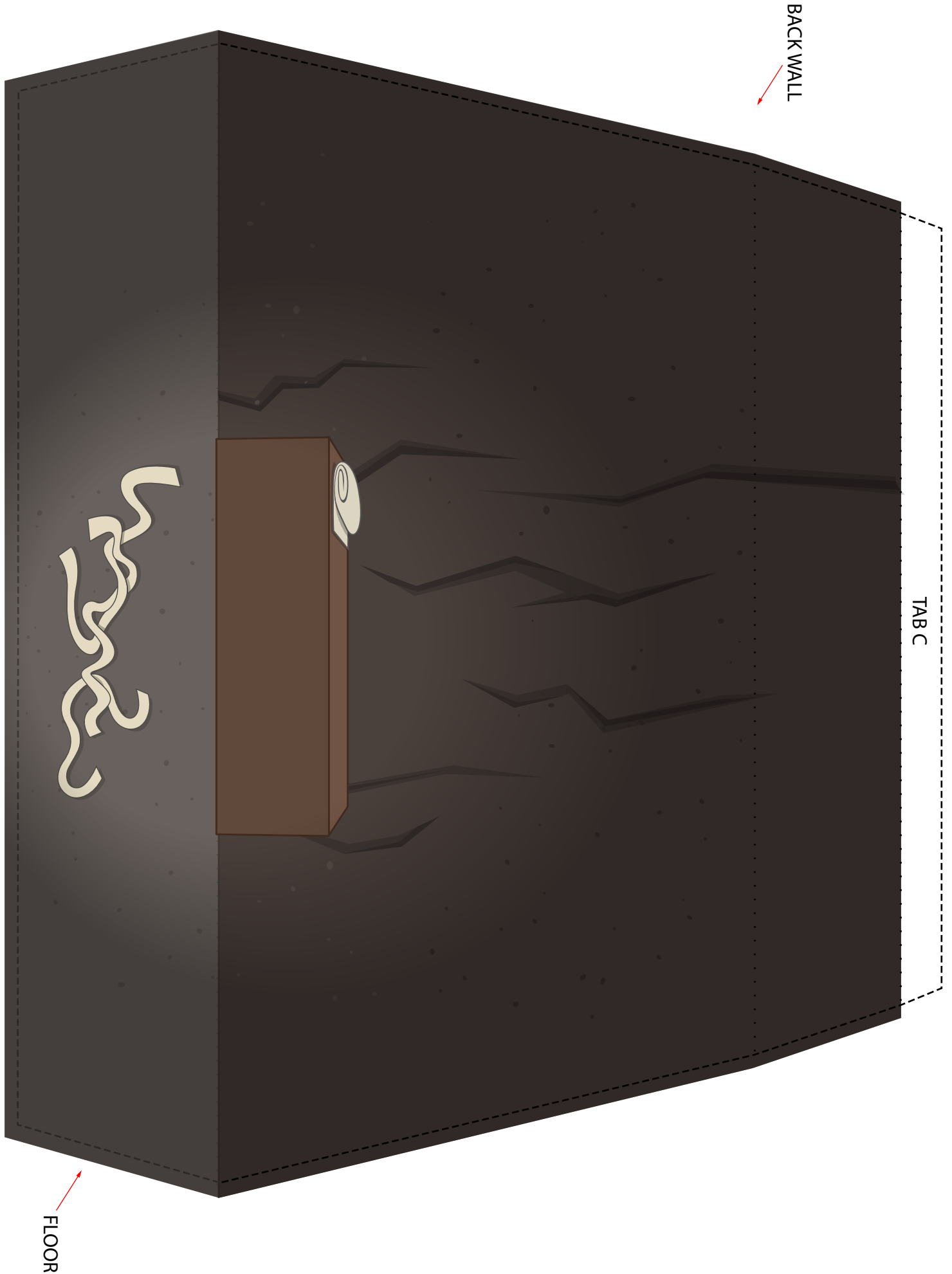

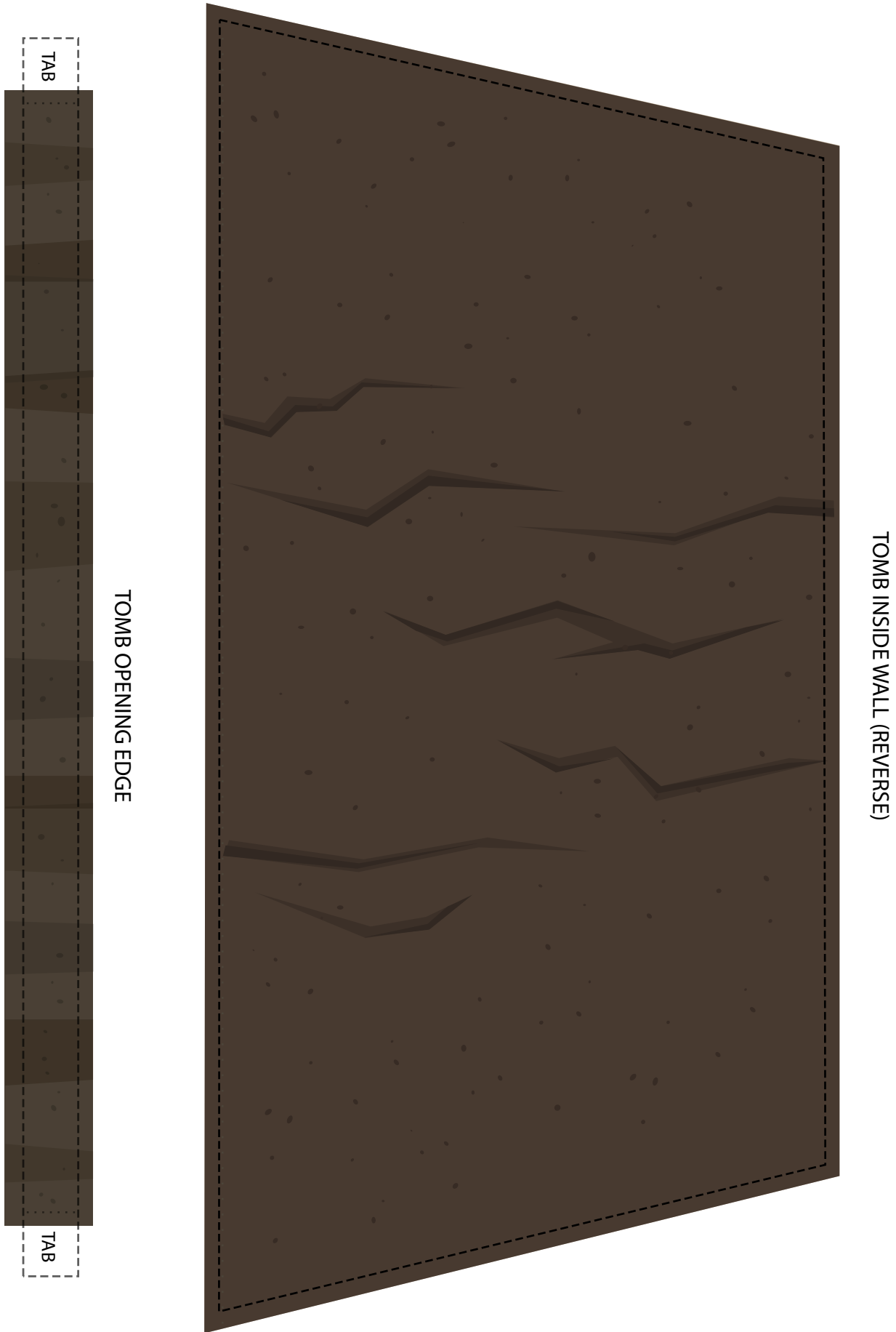



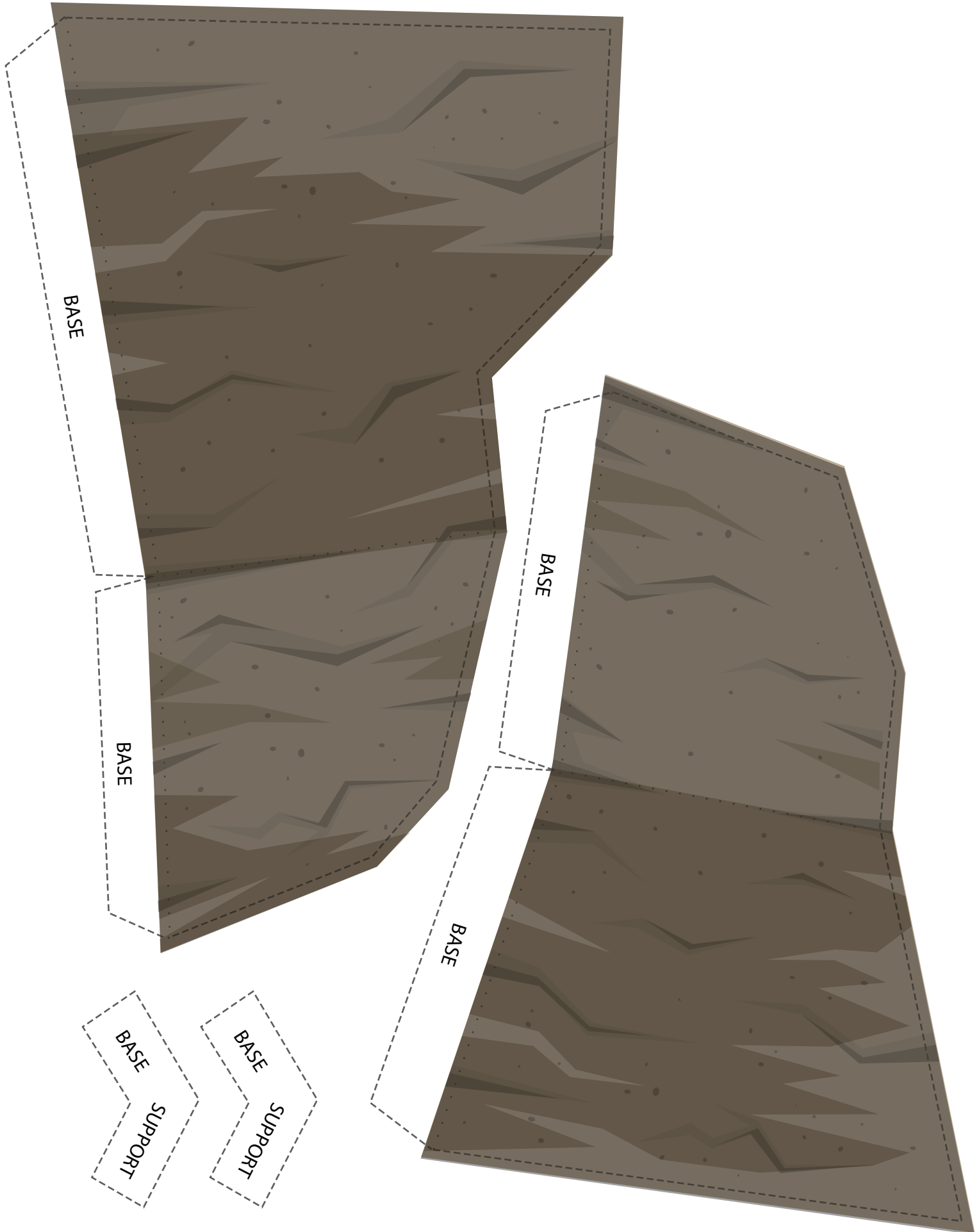

## JESUS' TOMB: EXTRAS

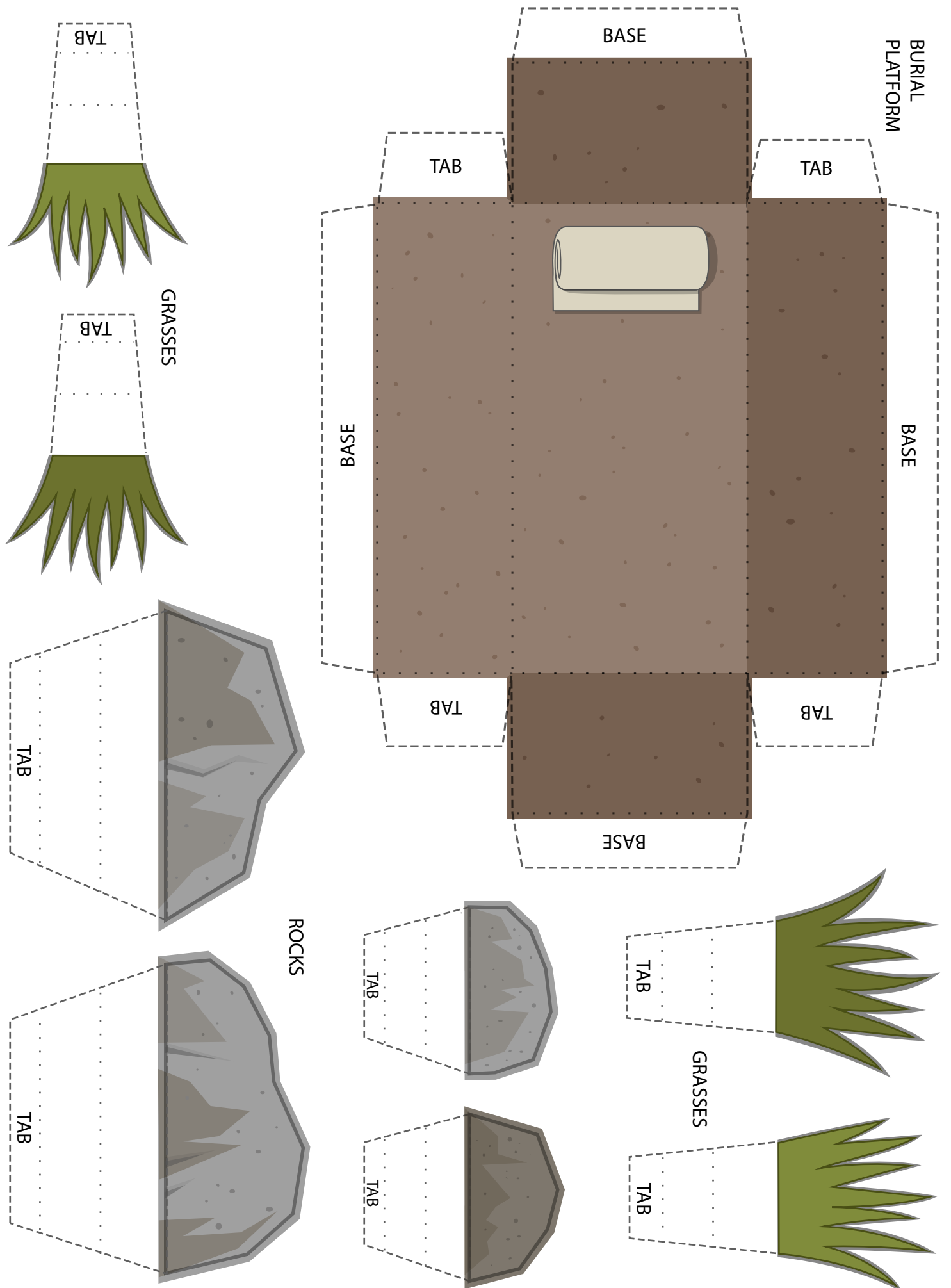

# JESUS' TOMB: ENTRANCE STONE

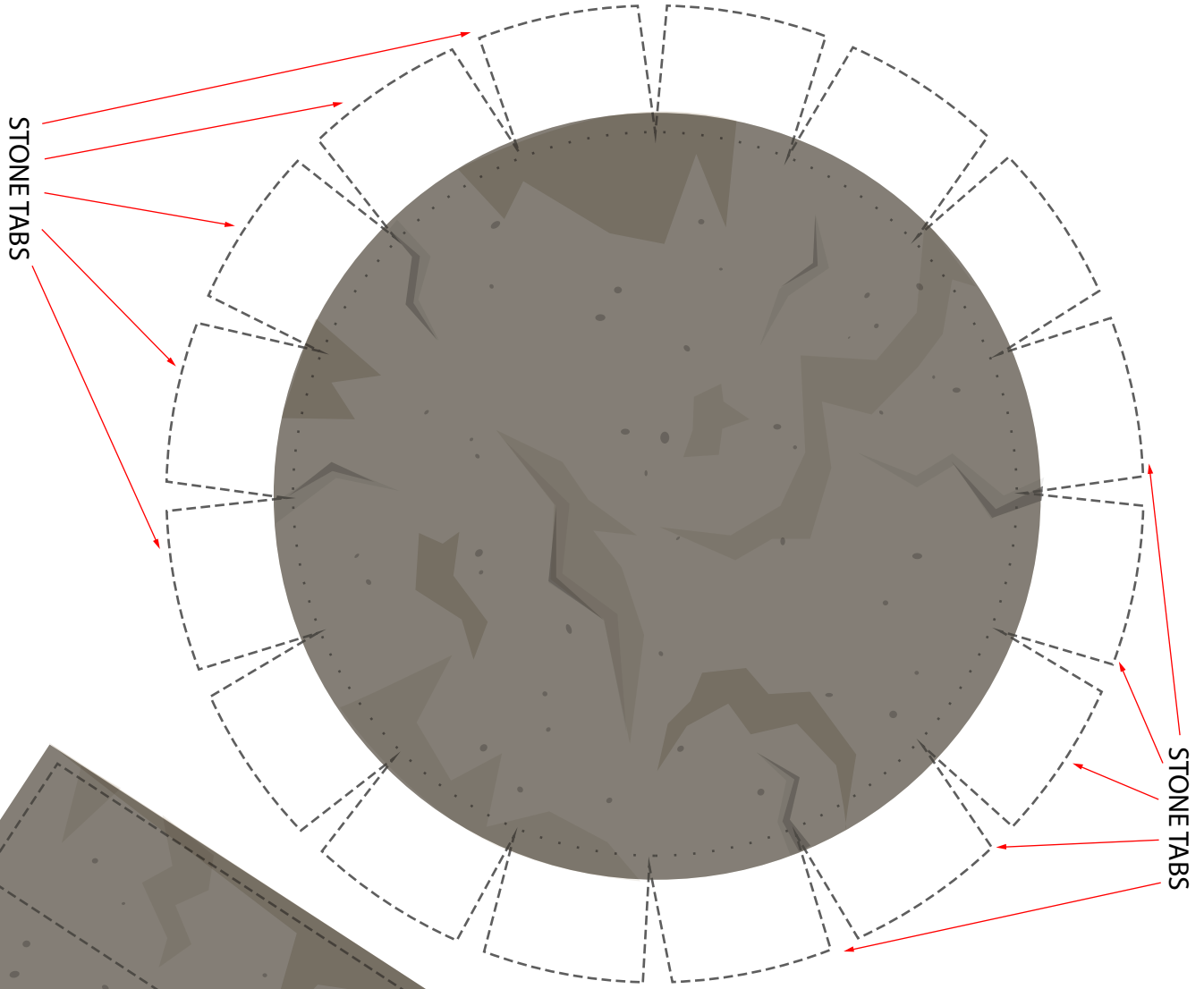

STONE TABS

STONE TABS

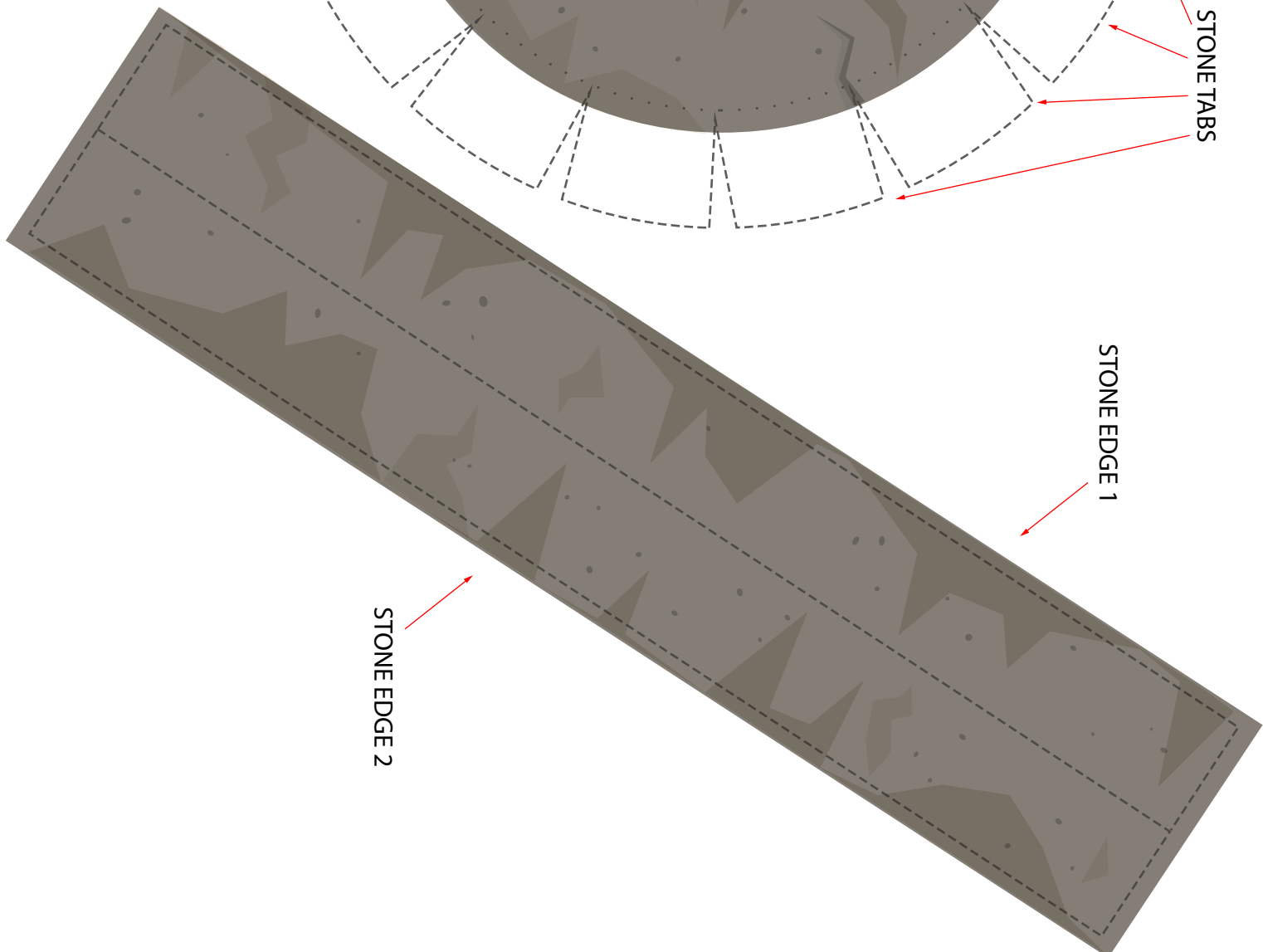

STONE EDGE 1

STONE EDGE 2



For best results, print the building elements onto heavier card stock (150-200 gsm if suitable for your printer). When glueing elements together, always allow a little time for drying before adding any other elements.

**STEP 1:** Print the sheets onto card stock. If scaling down the prints to better suit your printer's capabilities, be sure to scale down all the pages by the same amount (eg. 95%).

**STEP 2:** Cut out the individual parts ready for assembly; for better accuracy do a "rough cut" around the perimeter of each element first. Then select each element and "fine cut" along the dashed lines.

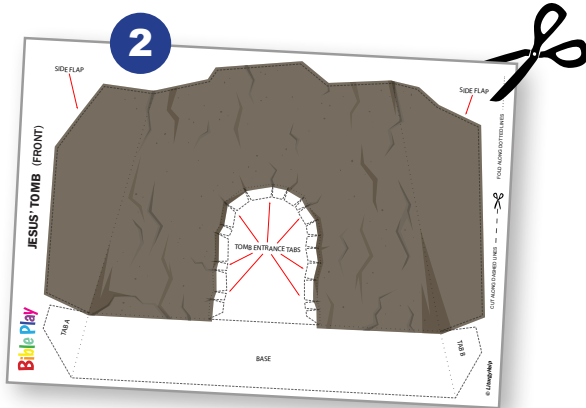

**STEP 3:** Begin assembly of **Tomb Front** section by mountain folding along all dotted lines, including all small tabs around the **Tomb Entrance**.

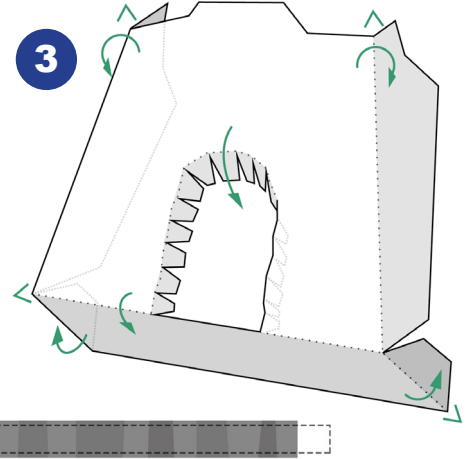

**STEP 4:** Cut out the **Tomb Entrance Edge** (on the **Tomb Extras** sheet) and fold back one end, leaving about 1 cm in from the end. Apply glue to back of the whole strip except for both ends – these will be glued to the **Tomb Floor** later.

Lay the **Tomb Front** section face-down and apply glue to front of the **Tomb Entrance Tabs**. Starting with the folded end, line up the **Tomb Entrance Edge** (matching the fold with the bottom corner of the entrance), and working one tab at a time, press firmly against each tab to ensure a strong hold. Fold back remaining end of the **Tomb Entrance Edge**.

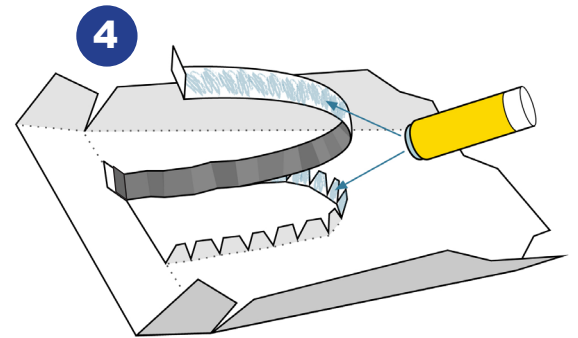

**STEP 5:** Cut and fold the **Tomb Inside** section and apply glue to bottom under-side edge. Apply glue to **Tomb Front Base** and stick both sections together.

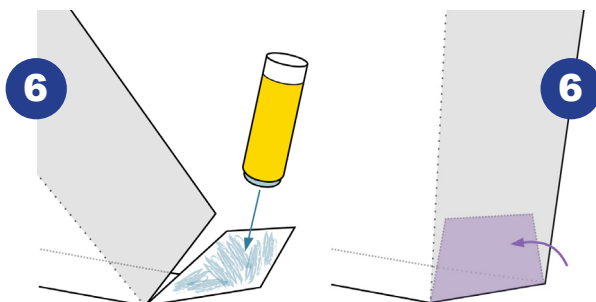
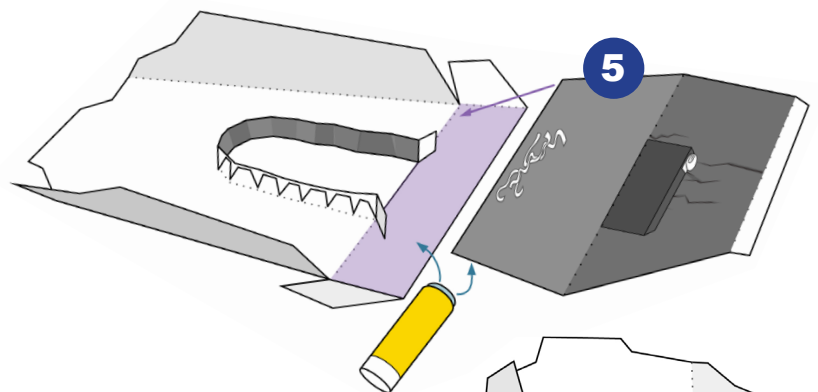
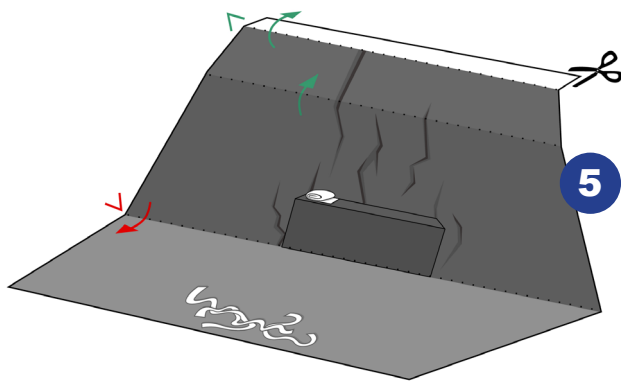

**STEP 6:** Apply glue to front of **Tab A** and **Tab B** and lift up **Tomb Front** section along front bottom edge, so that the **Tabs** stick firmly to the under-sides of the **Side Flaps**.

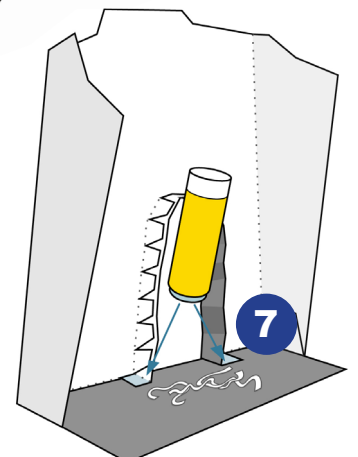

**STEP 7:** Apply glue to the folded-back ends of the **Tomb Entrance Edge** and press down on the **Tomb Floor**.



**STEP 8:** Apply glue to **Tab C**, lift the **Tomb Wall** and press tab to the back of the **Tomb Front**.

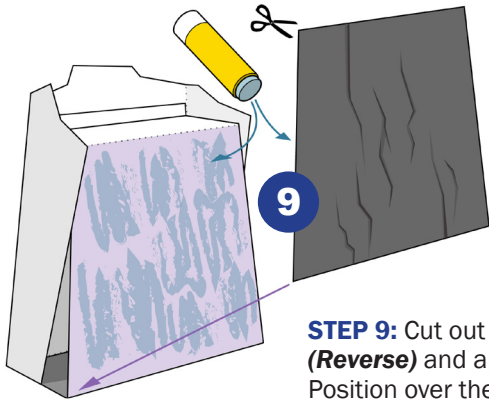
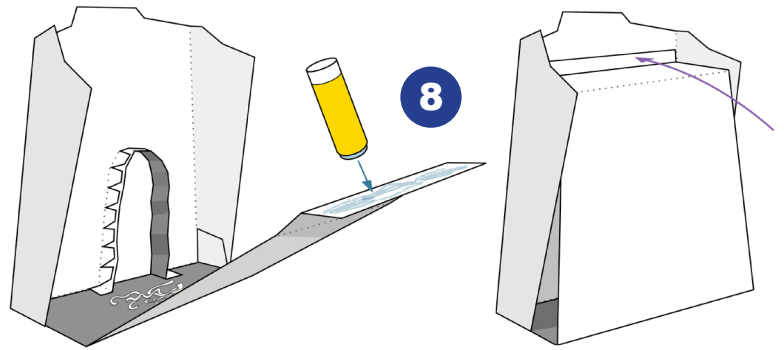

**STEP 9:** Cut out the **Tomb Wall (Reverse)** and apply glue to the back. Position over the back of the **Tomb Wall (Front)** and press firmly.

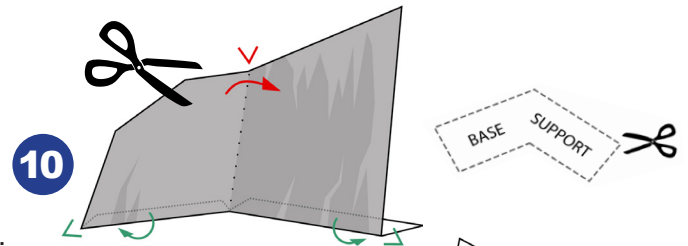

**STEP 10:** Cut out and fold the **Tomb Sides**.

**STEP 11:** Cut out and glue the **Base Support** to the base of each **Tomb Side**.

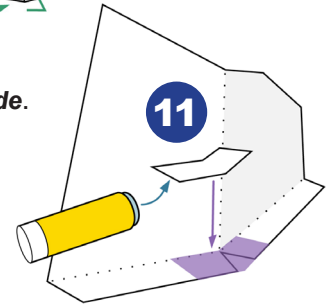

**STEP 12:** Apply glue to back of each **Tomb Side** and press against the **Tomb Front Side Flaps** – lining up against the front edges of the **Tomb Front**.

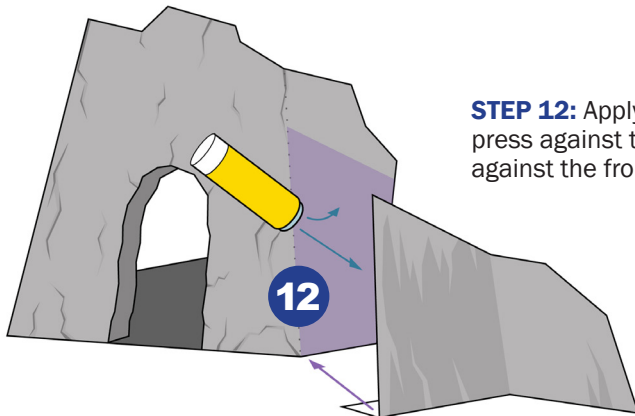

**STEP 13:** Cut out and fold the **Burial Platform**.

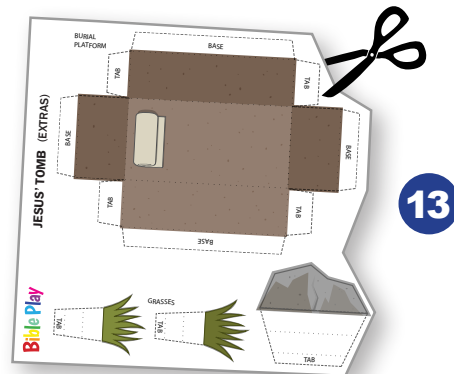

**STEP 14:** Apply glue to the **Burial Platform Tabs**. Pull down the platform sides and press tabs in behind the shortest sides to form a rectangular box.

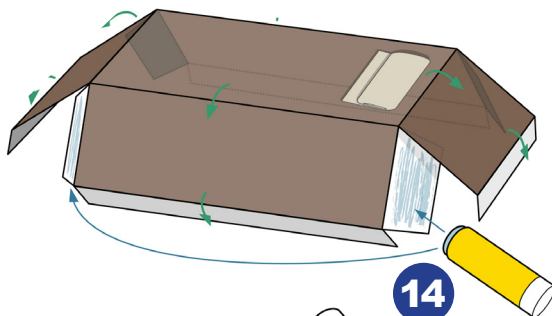

**STEP 15:** Apply glue to the under-side of the **Base** corners and press down.

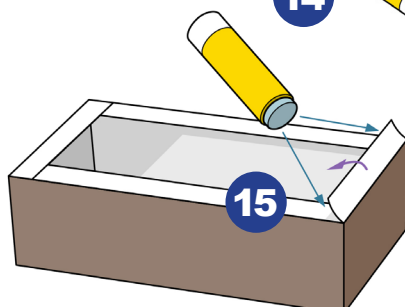

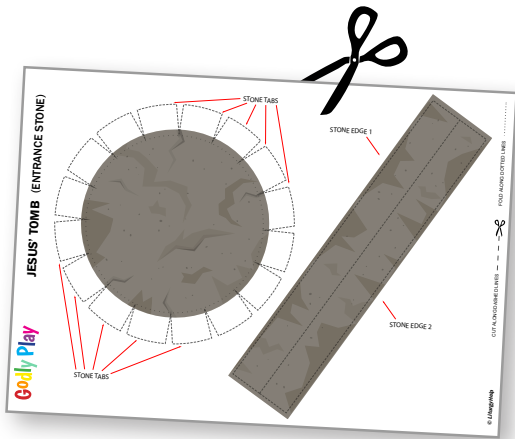

16

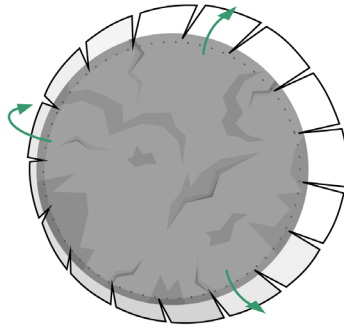

**STEP 16:** Cut out the **Entrance Stone** and fold back the tabs.

**STEP 17:** Cut out the **Stone Edges** and join them together with glue.

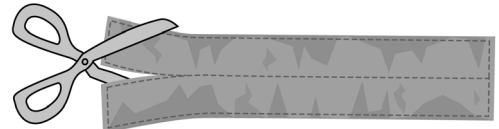

17

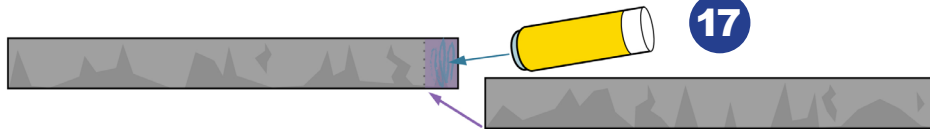

18

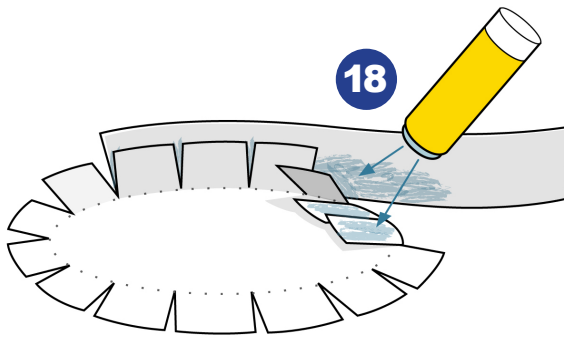

**STEP 18:** Apply glue to the back of the **Stone Edge** and front of the **Stone Tabs**. Working one tab at a time, press **Stone Edge** firmly against each tab to ensure a strong hold.



**STEP 19:** Cut out and fold the **Rocks and Grasses**.

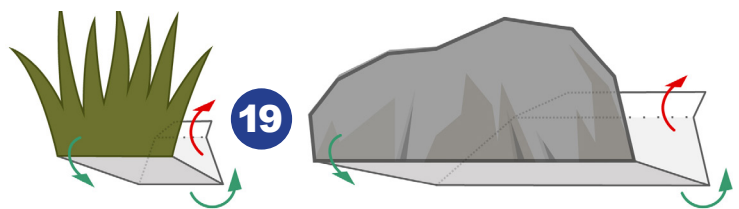

19

**STEP 20:** Apply glue to the back of the **Rocks and Grasses Tabs** and press firmly to the back of the cut-outs.

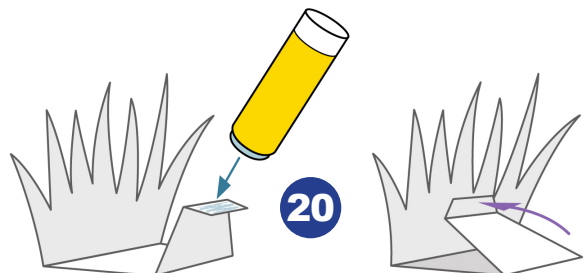

20

# PETER'S HOUSE: FRONT



# PETER'S HOUSE: SIDE

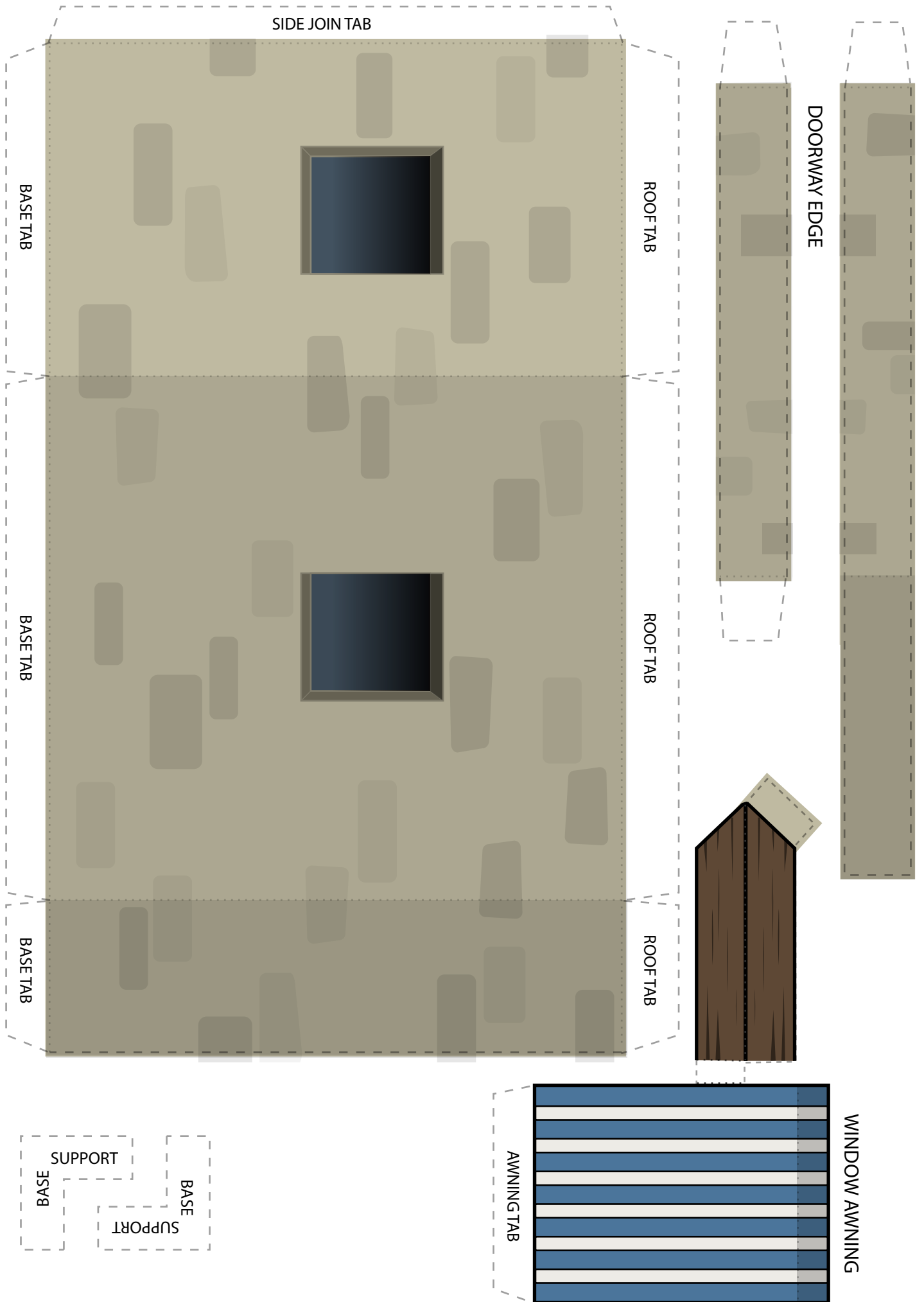



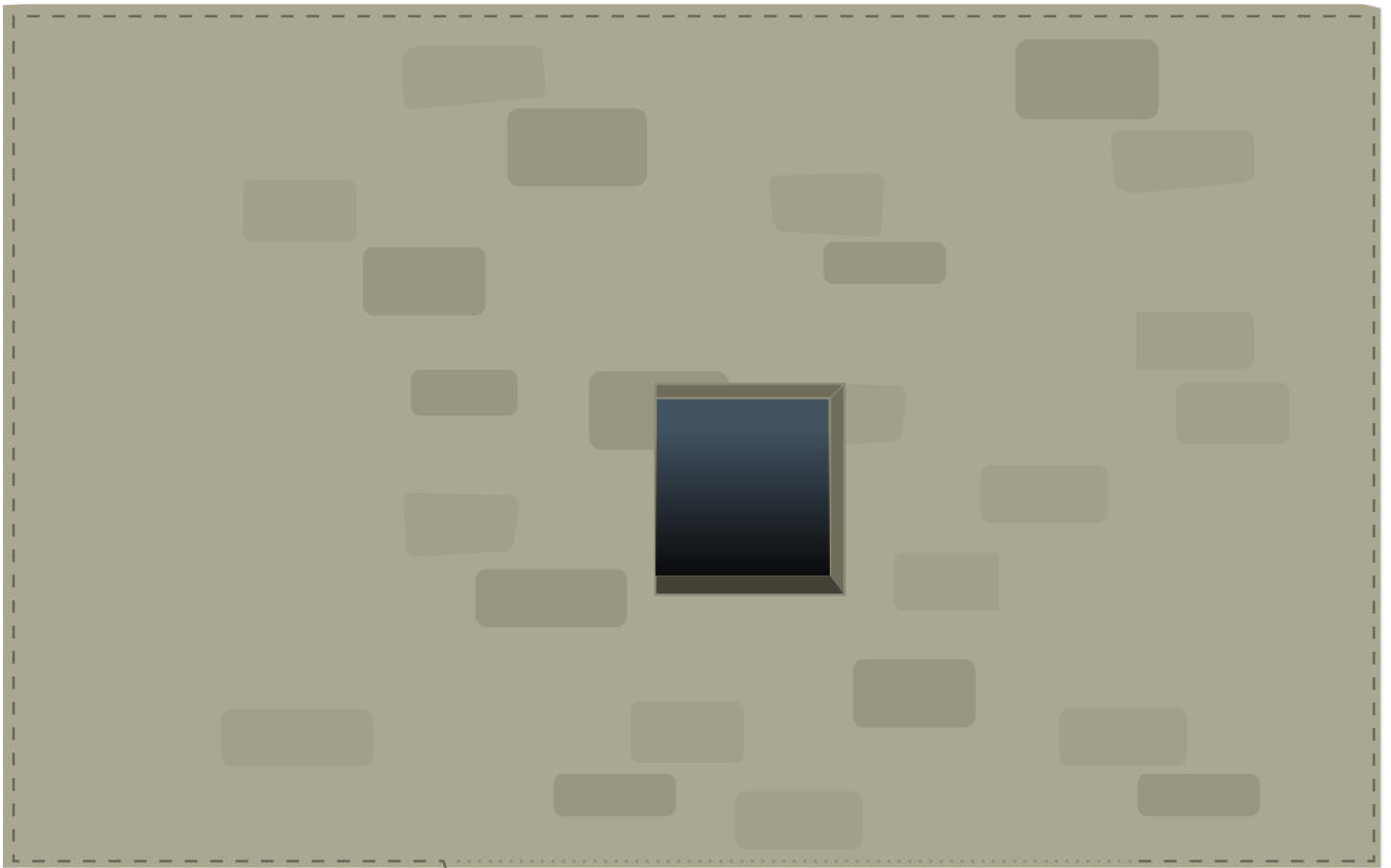

ROOF TAB

ROOF TABS

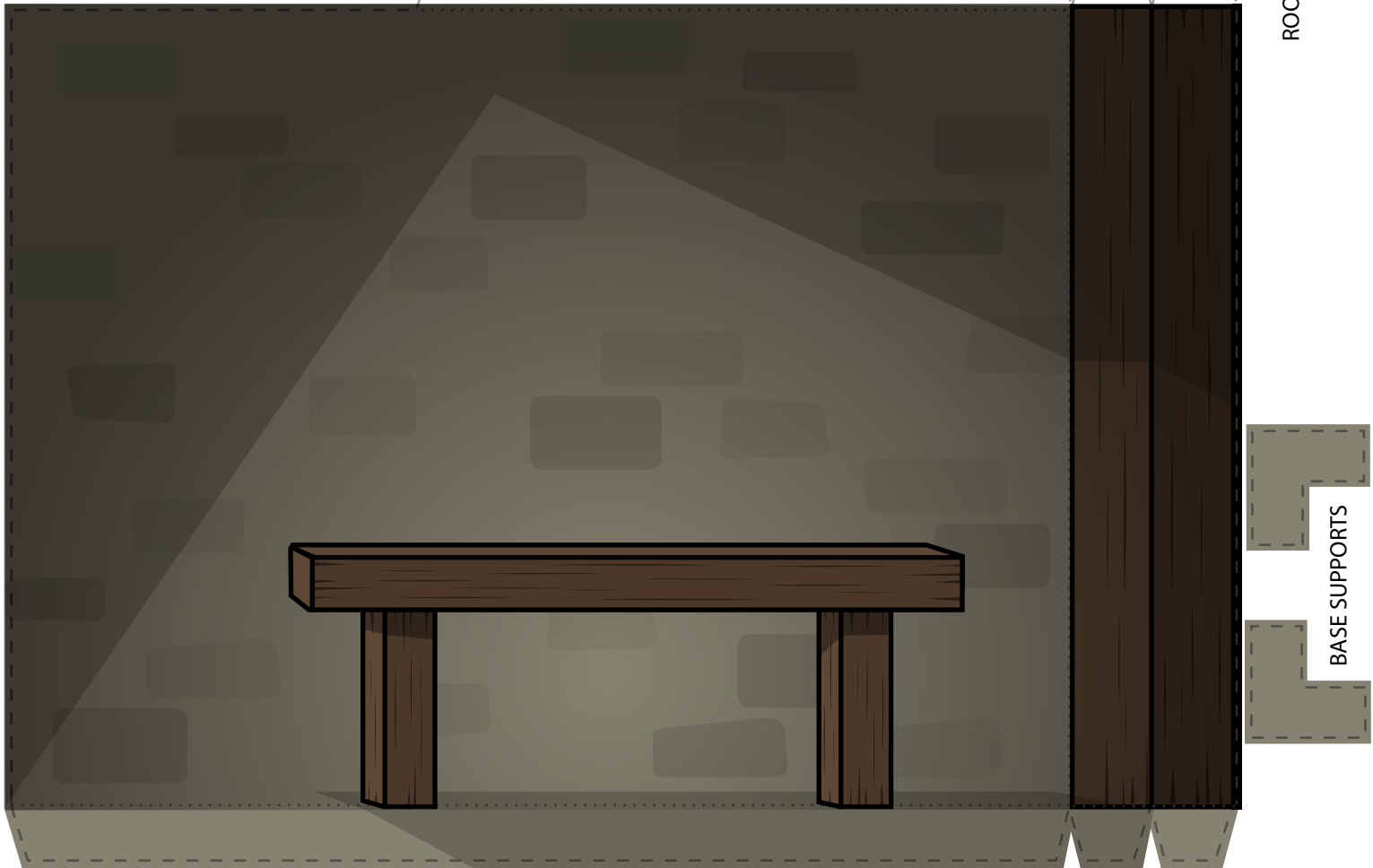

BASE TABS

BASE SUPPORTS





For best results, print the building elements onto heavier card stock (150-200 gsm if suitable for your printer). When glueing elements together, always allow time for drying before adding any other elements.

**STEP 1:** Print the sheets onto card stock. If scaling down the prints to better suit your printer's capabilities, be sure to scale down all the pages by the same amount (eg. 95%).

**STEP 2:** Cut out the individual parts ready for assembly; for better accuracy do a "rough cut" around the perimeter of each element first. Then select each element and "fine cut" along the dashed lines.

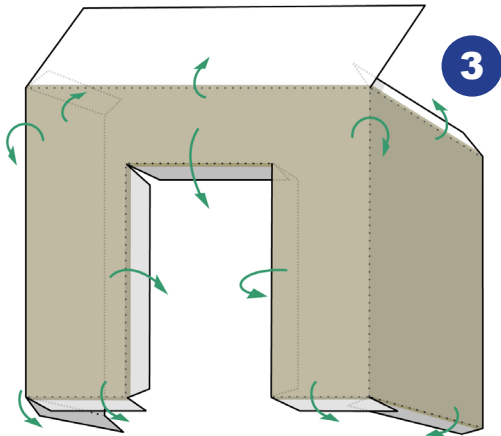

**3**

**STEP 3:** Begin assembly of **House Front** section by mountain folding along all dotted lines.

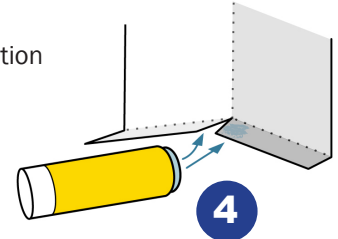

**4**

**STEP 4:** Apply glue to the overlapping areas of the **Base Tabs** and **Roof Tabs** and press them together – setting the **House Front** corners to 90°.

**STEP 5:** Apply glue to one of the **Doorway Edge Tabs** to join the two sections together and fold along all dotted lines.

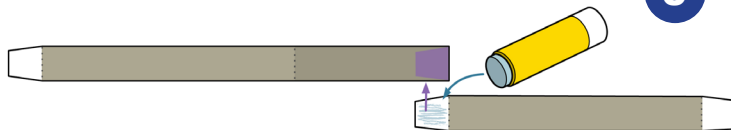

**5**

**STEP 6:** Apply glue to back of the **Doorway Edge** and press against the Doorway Tabs. Finish off by glueing the two **Doorway Edge Tabs** and pressing to the **House Front Base Tabs**.

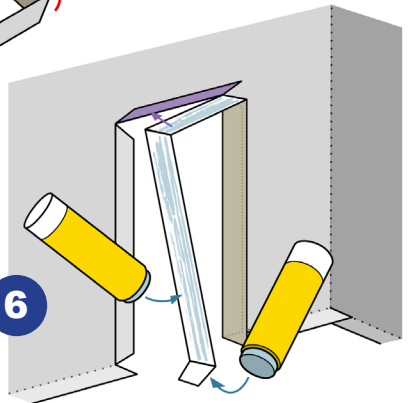

**6**

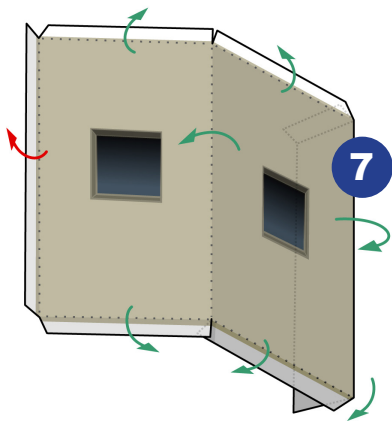

**7**

**STEP 7:** Cut out and fold the **House Side** section. Apply glue to the overlapping areas of the **Base Tabs** and **Roof Tabs** and press them together – setting the **House Side** corners to 90°.

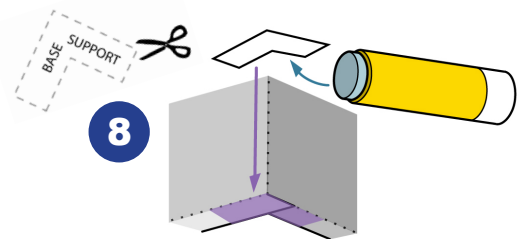

**8**

**STEP 8:** Cut out the **Base Supports** and glue them into the the lower corners for additional support.

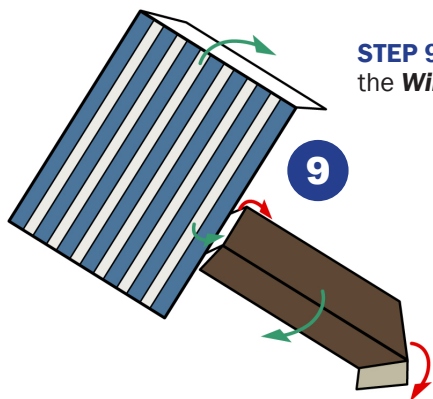

**9**

**STEP 9:** Cut out and fold the **Window Awning**.

**STEP 10:** Apply glue to the back of the **Indent** and press down against the back of the **Window Awning**. Apply glue to the back of the **Timber Support** and fold it back on itself.

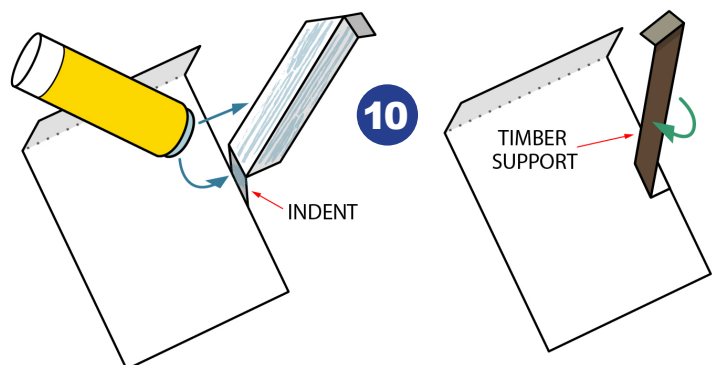

**10**

## PETER'S HOUSE: INSTRUCTIONS

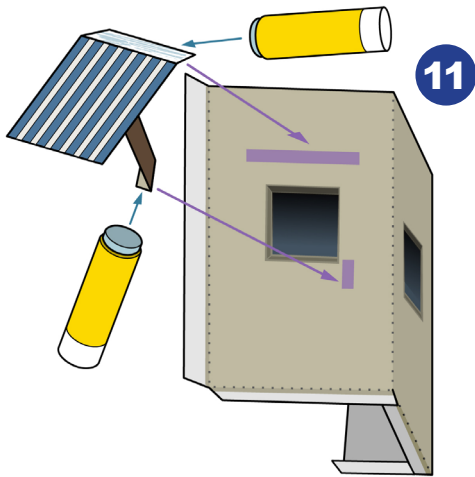

**STEP 11:** Apply glue to back of the **Window Awning Tab** and **Timber Support Tab**. Place above front window of the **House Side** section and press firmly.

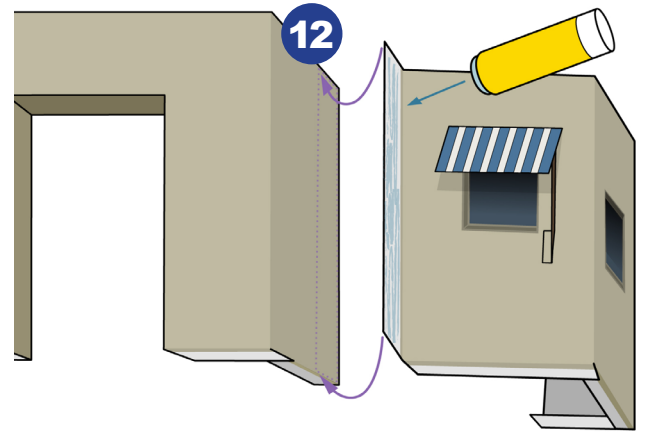

**STEP 12:** Apply glue to the **Side Join Tab**. Position **House Side** section in behind **House Front** section and press firmly.

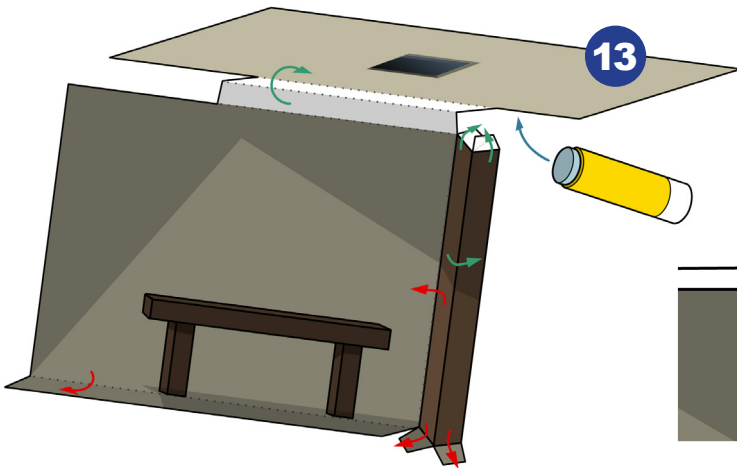

**STEP 13:** Cut out and fold the **Side/Inside** section. Apply glue to back of the **Side** and **Inside** panels and long **Roof Tab** and press them firmly together.

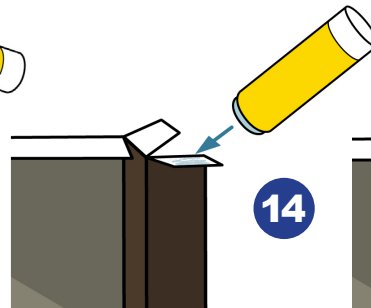

**STEP 14:** Apply glue to back of one small **Roof Tab** and press down firmly on the other.

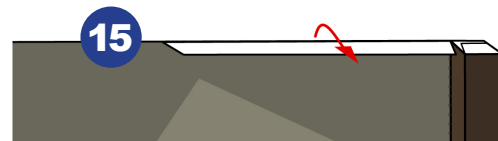

**STEP 15:** Fold over long **Roof Tab** in towards the **Inside** panel.

**STEP 16:** Cut out the **Base Support** and glue on top of **Base Tabs**, setting the **Timber Post** corner to 90°.

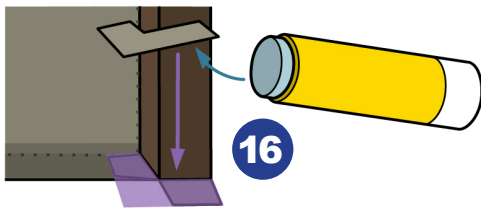

**STEP 17:** Apply glue to inside of **House Front** side panel and corresponding base. Position **Side/Inside** section inside **House Front** section and press firmly into the corner.

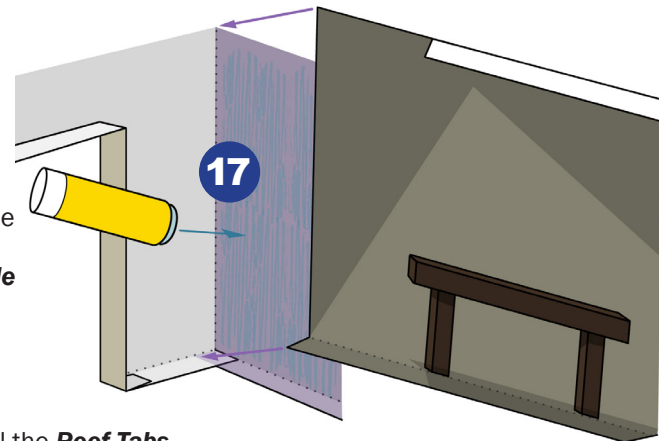

**STEP 18:** Apply glue to all the **Roof Tabs**.

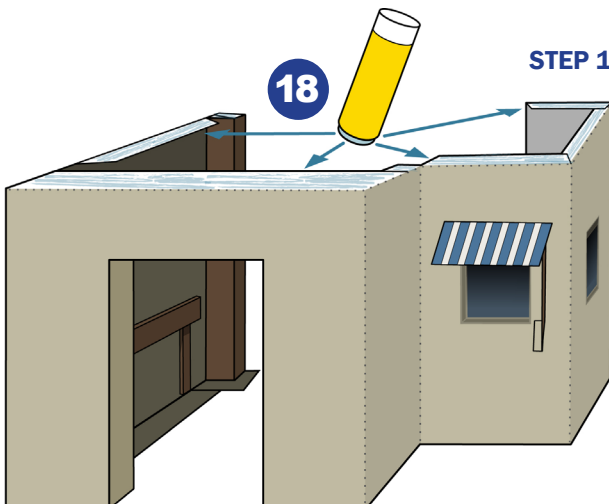

**STEP 19:** Cut out the **Roof** section and press onto **Roof Tabs**. There should be a small overhang around the front and sides.

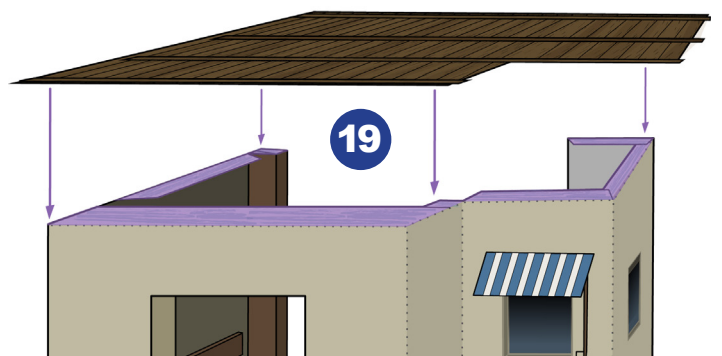

HOUSE 1: FRONT/OUTSIDE

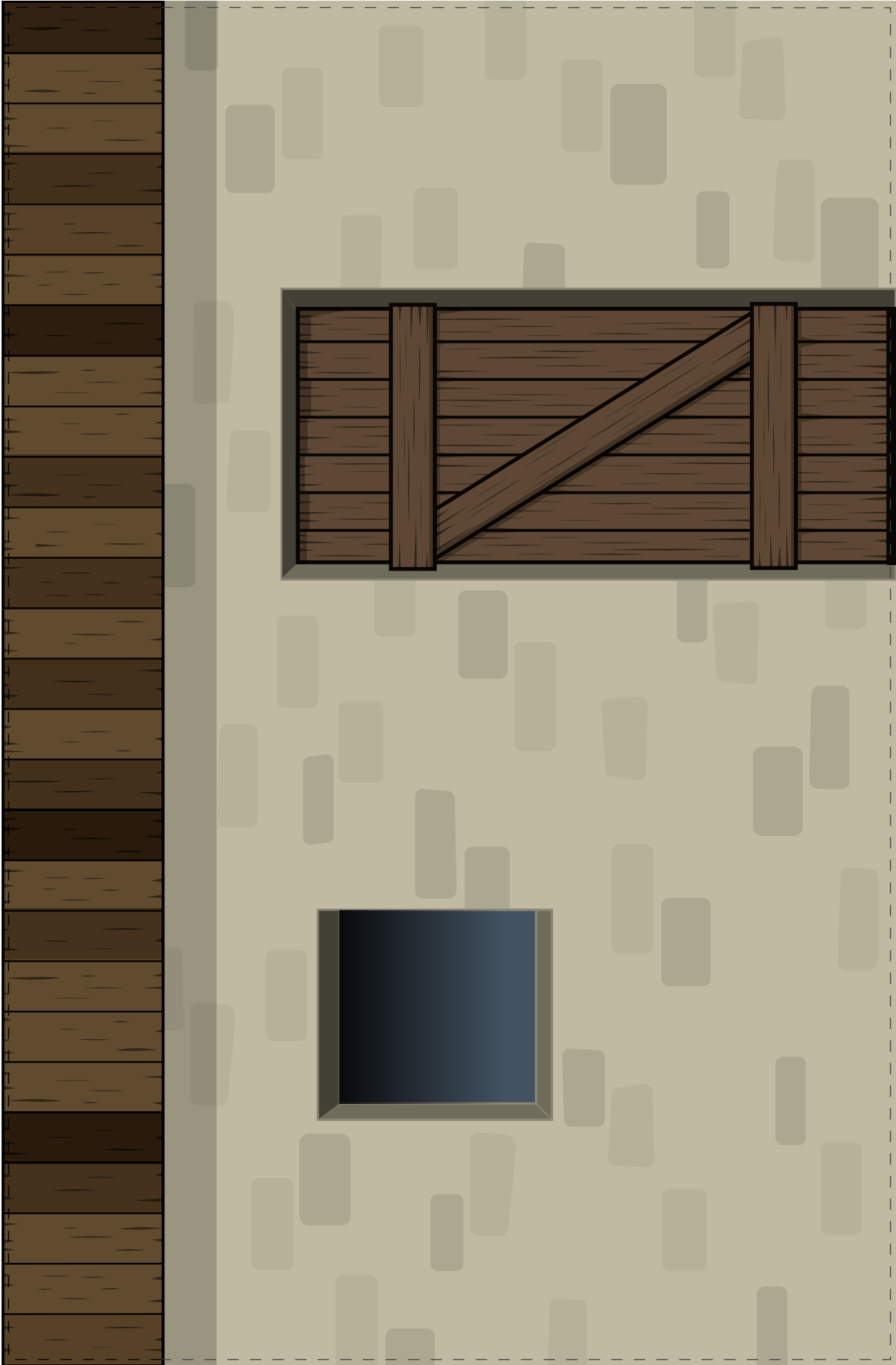



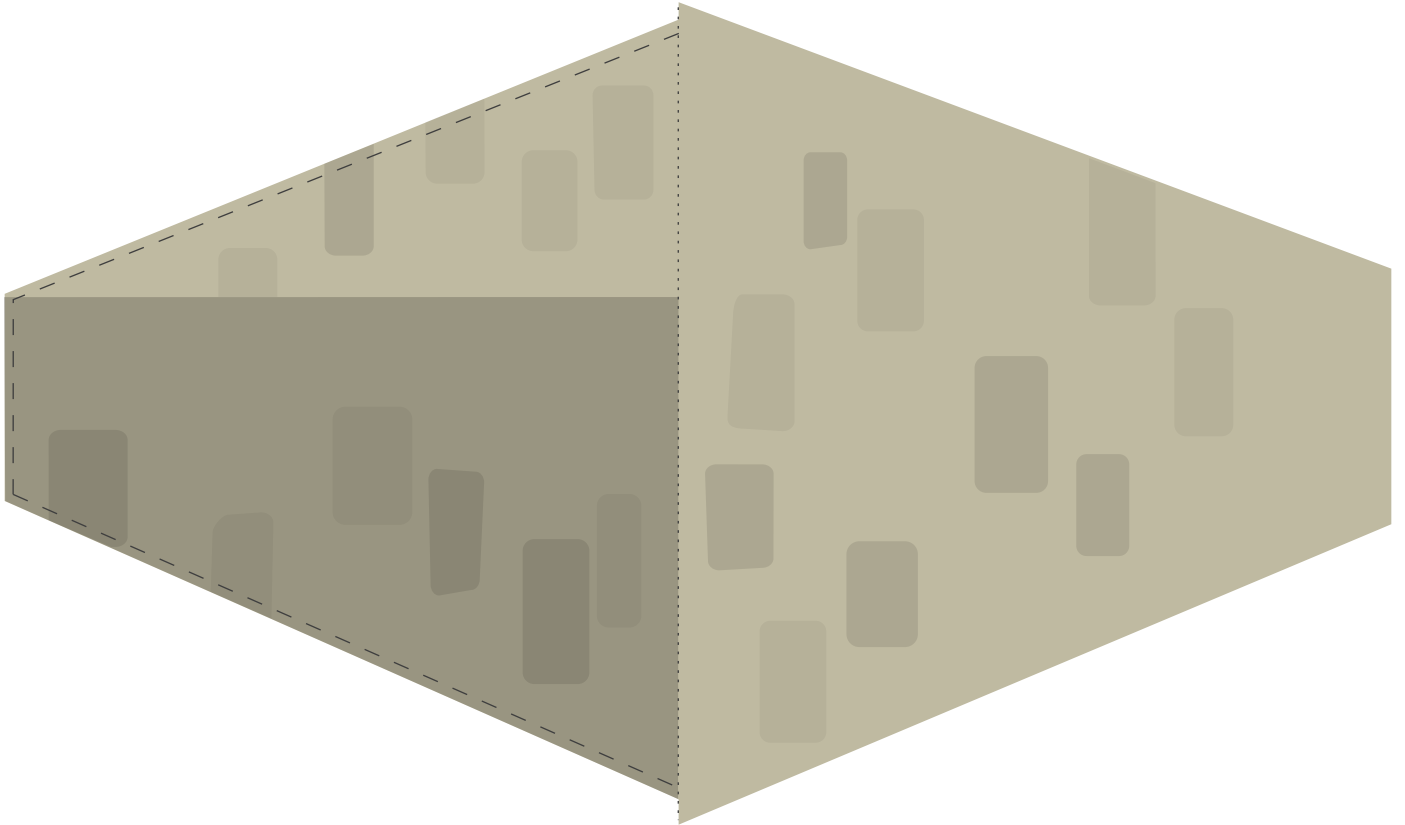
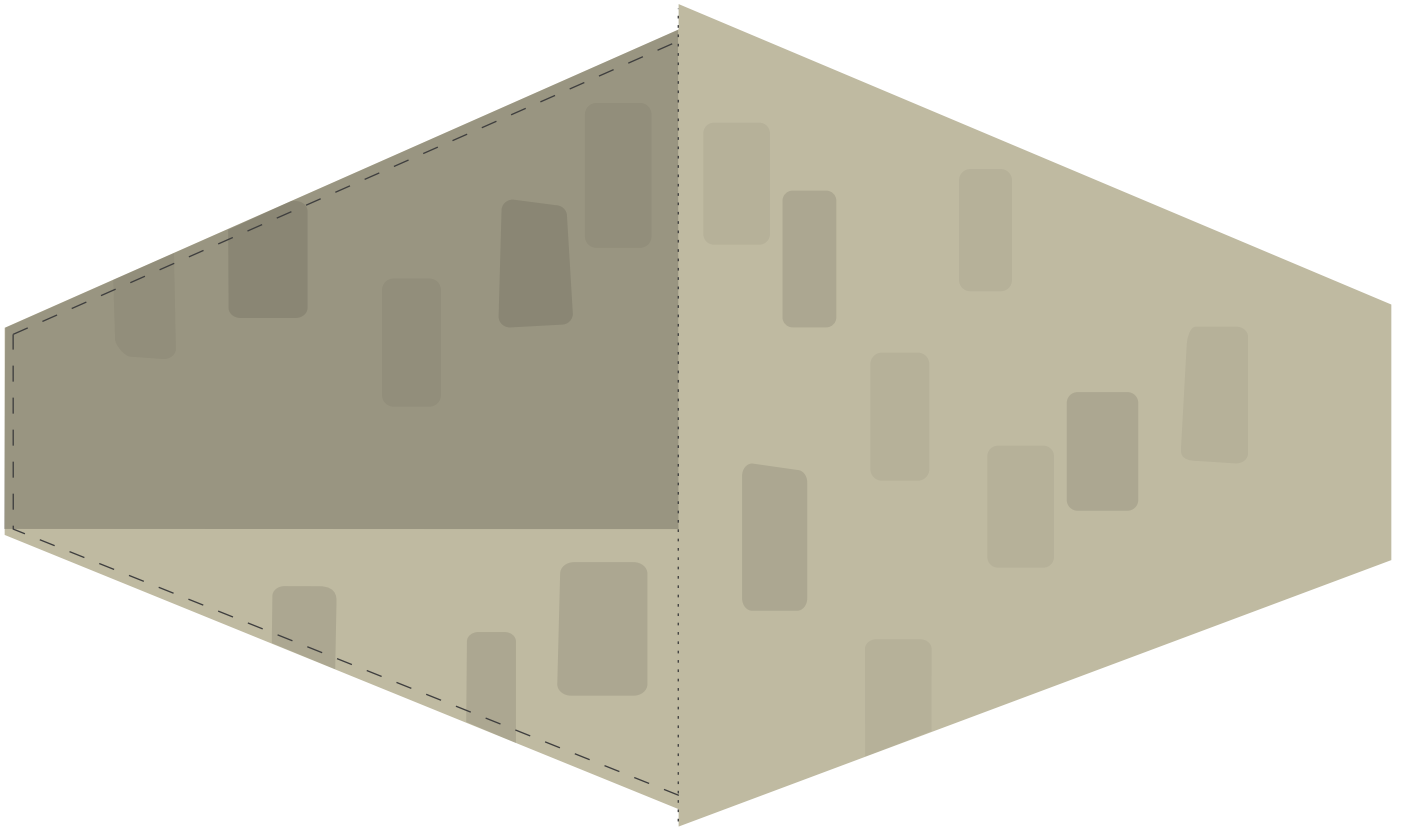

For best results, print the building elements onto heavier card stock (150-200 gsm if suitable for your printer). When glueing elements together, always allow time for drying before adding any other elements.

**STEP 1:** Print the sheets onto card stock. If scaling down the prints to better suit your printer's capabilities, be sure to scale down all the pages by the same amount (eg. 95%).

**STEP 2:** Cut out the individual parts ready for assembly; for better accuracy do a "rough cut" around the perimeter of each element first. Then select each element and "fine cut" along the dashed lines.

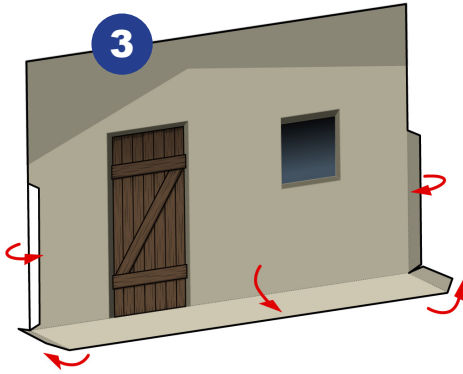

**STEP 3:** Cut out the **House Inside** section and fold along all dotted lines.

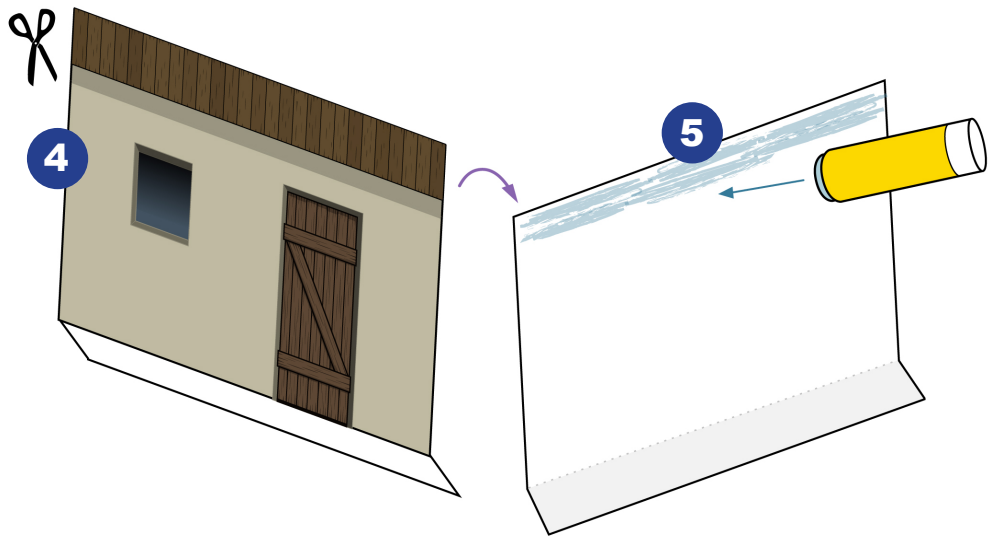

**STEP 4:** Cut out the **House Front/Outside** section.

**STEP 5:** Apply glue along the top of the reverse-side of **House Front/Outside** section.

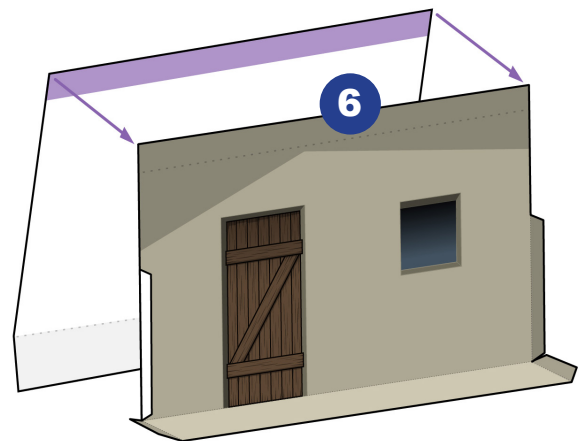

**STEP 6:** Line up the top edges of both **House** sections and firmly press together.

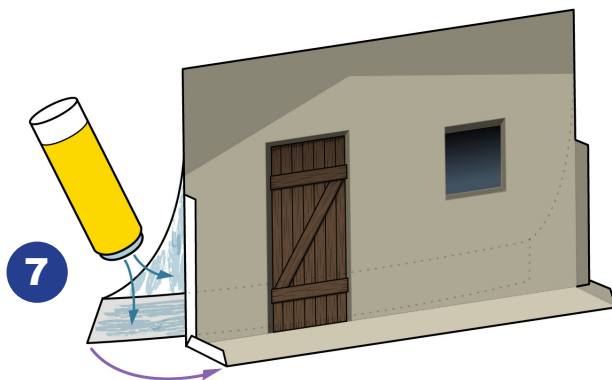

**STEP 7:** Continue to apply glue to the back of the **House Front/Outside** section, then carefully smoothing downwards from the top (to help remove any air bubbles), press both sections firmly together.





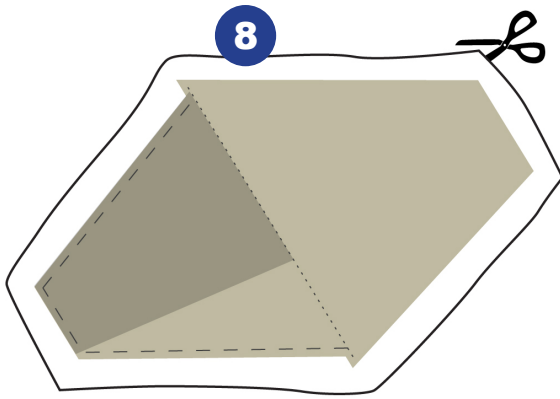

**STEP 8:** Rough cut around the **House Side** sections; leaving approximately a 1cm buffer.

**STEP 9:** Fold along the dotted lines of each section.

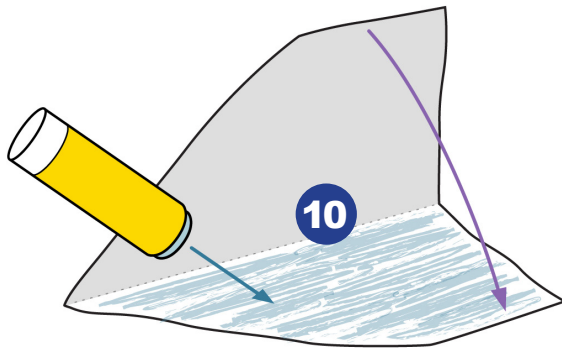
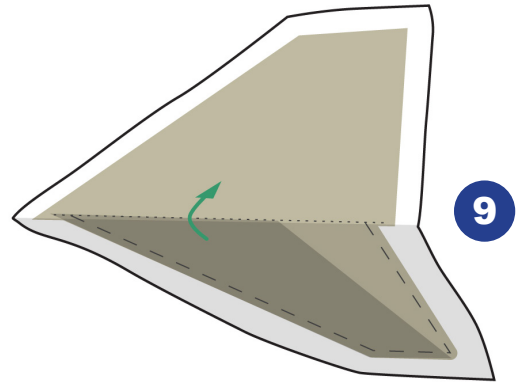

**STEP 10:** Apply glue to the insides of each **House Side** section and fold down, press firmly. Allow each piece to dry.

**STEP 11:** Fine cut along the dashed lines of each **House Side** section.

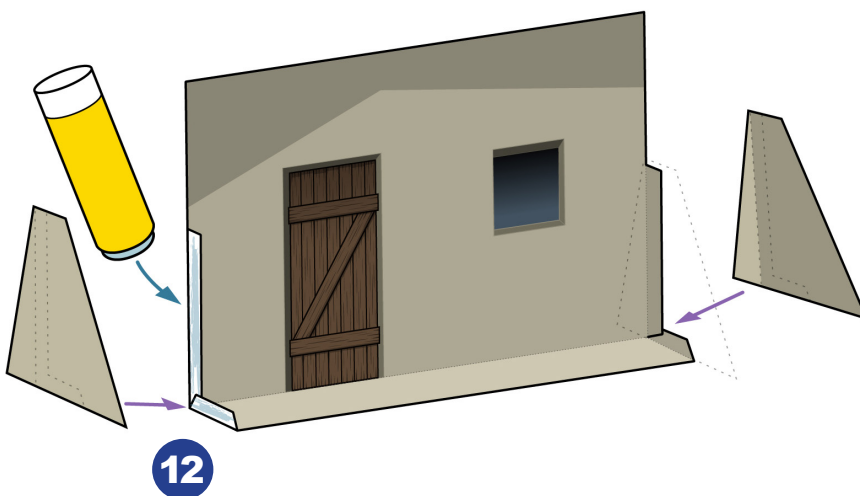
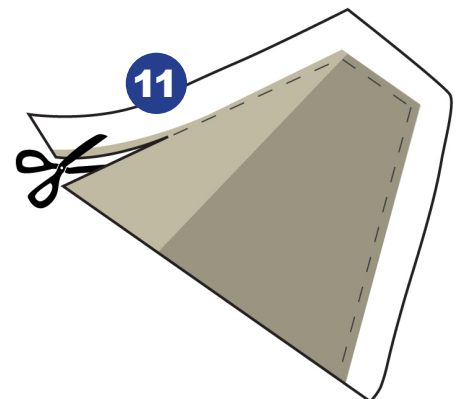

**STEP 12:** Apply glue to side tabs of the **House** section and position each **Side** piece so that the darker shade areas are facing inwards

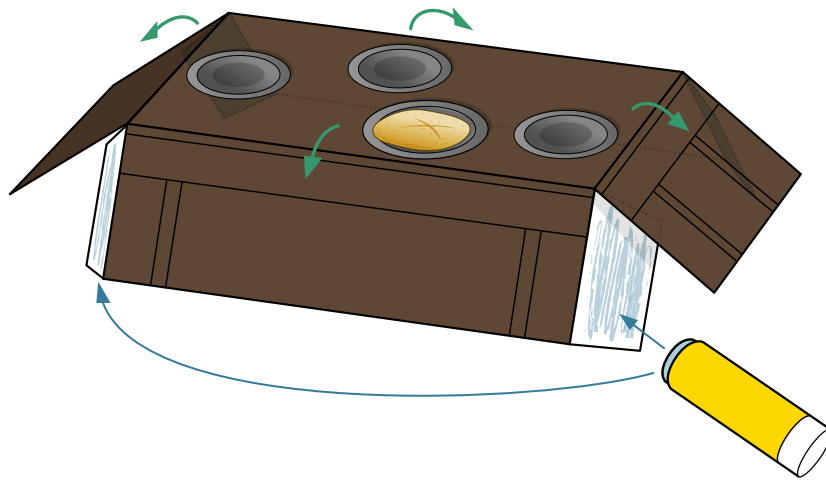
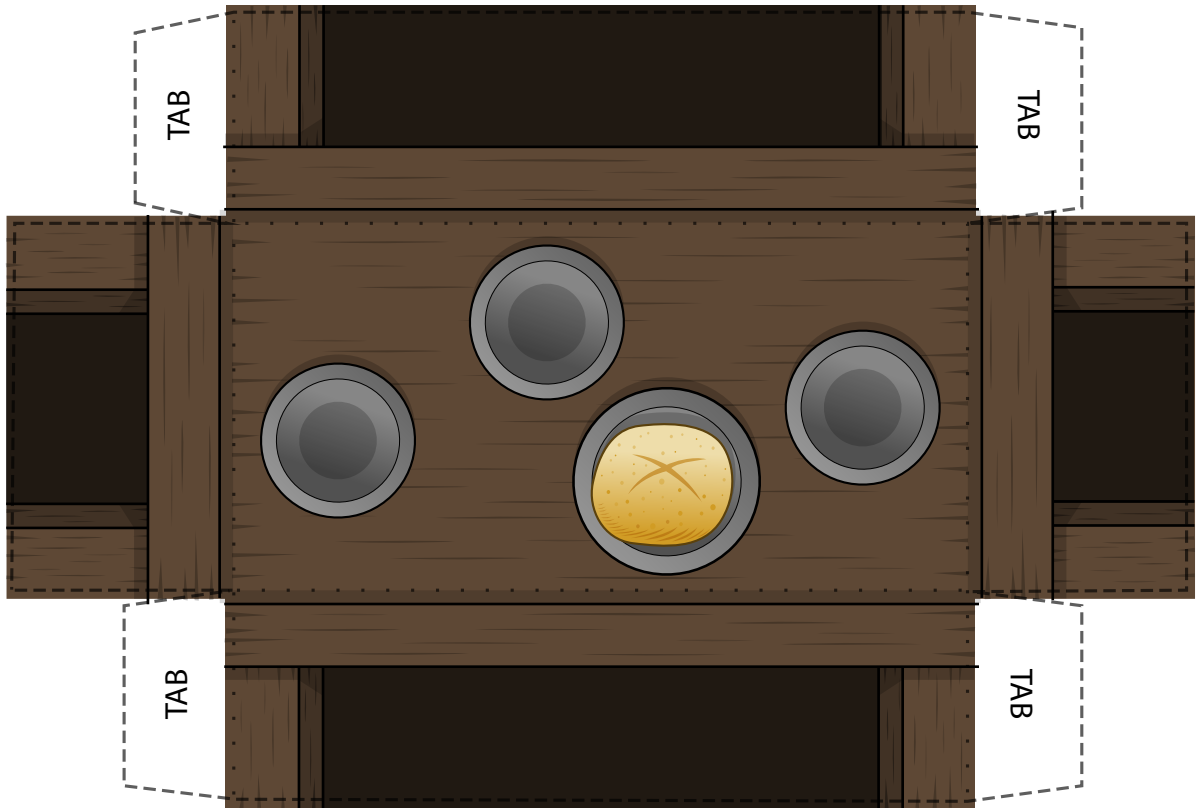

**INSTRUCTIONS:** Cut out and fold the **Table**. Apply glue to the **Tabs**. Pull down the table sides and press tabs in behind the shortest sides to form a rectangular box.

# ROCKS AND GRASSES

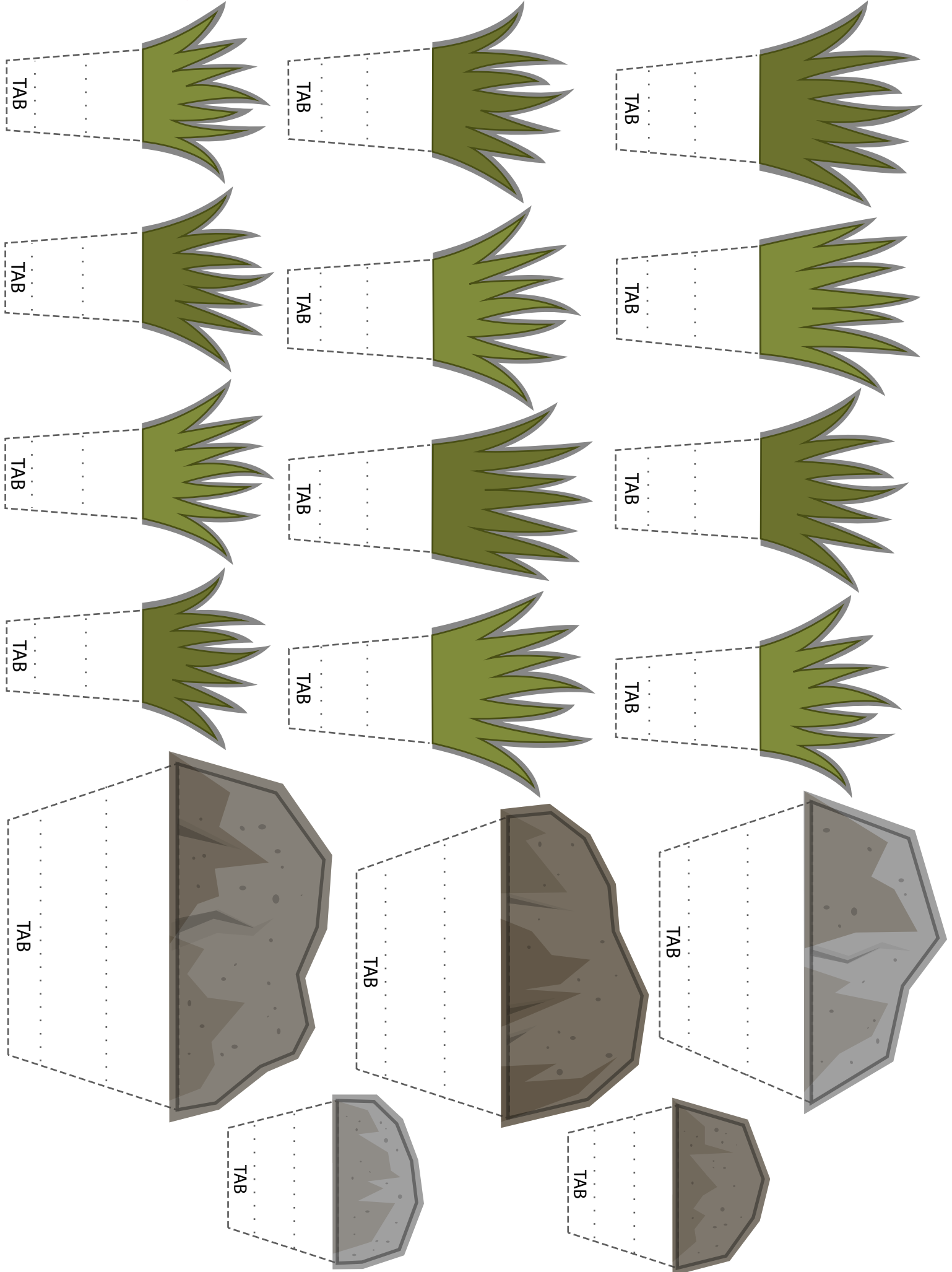

## TREE 1

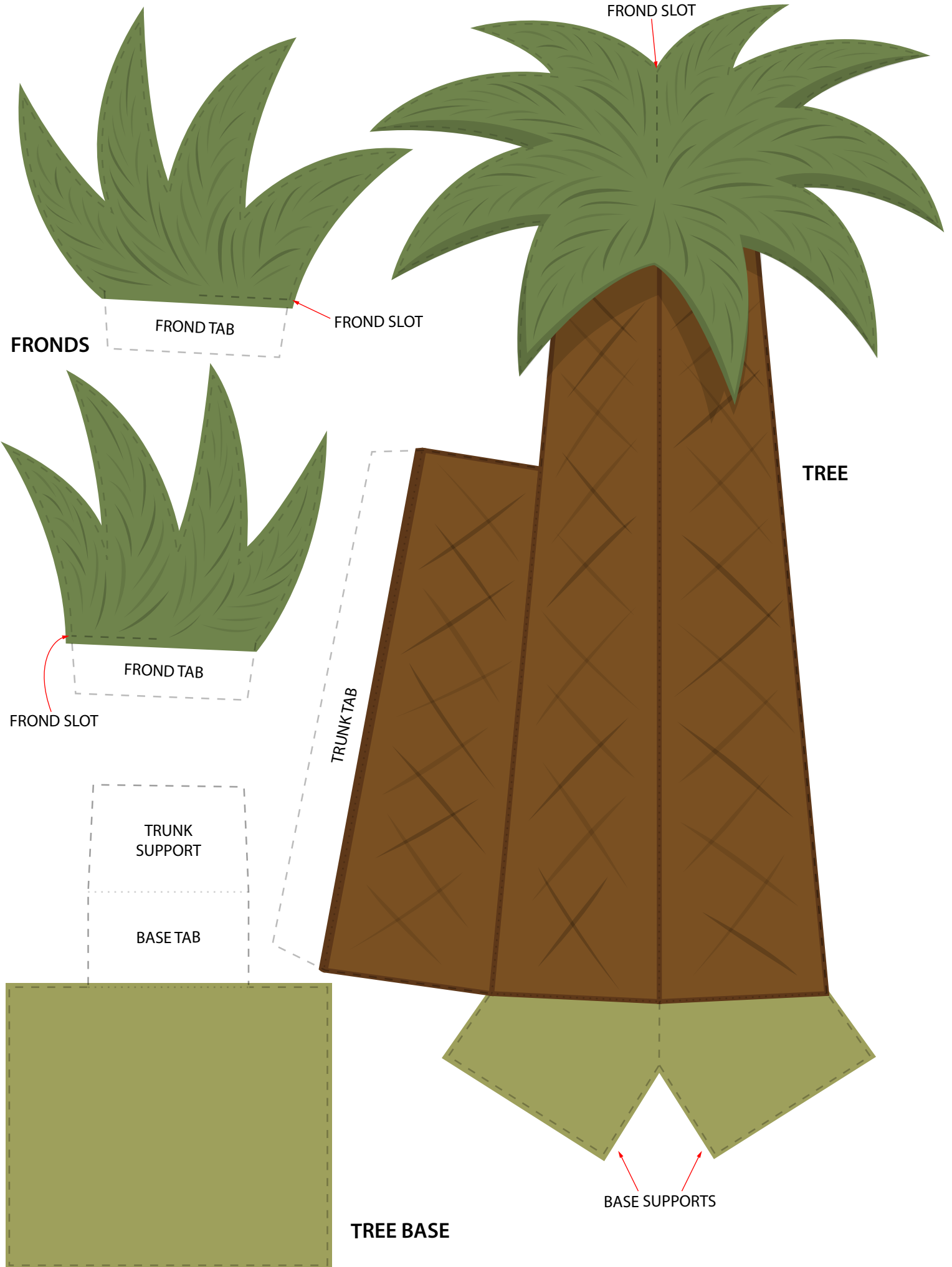

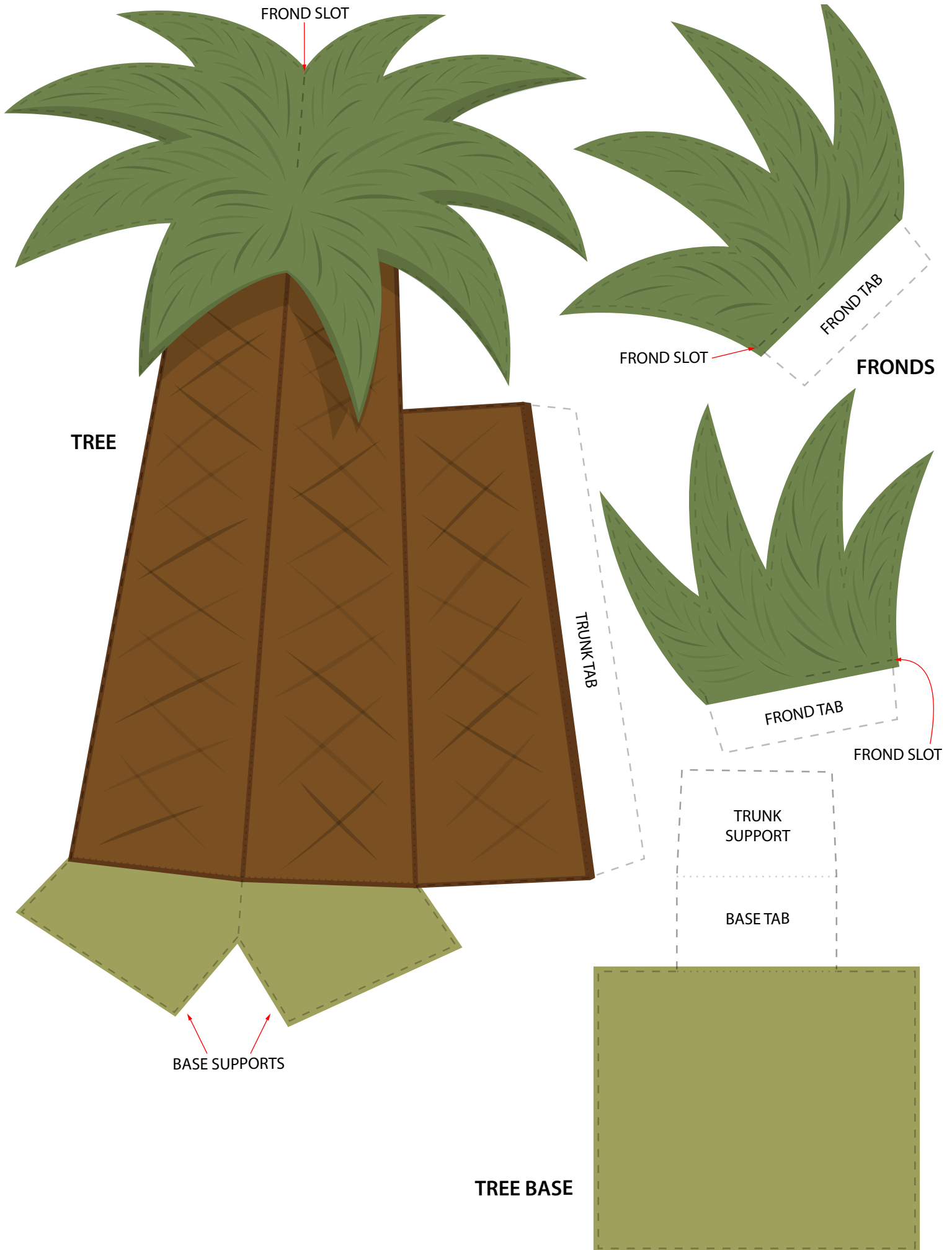

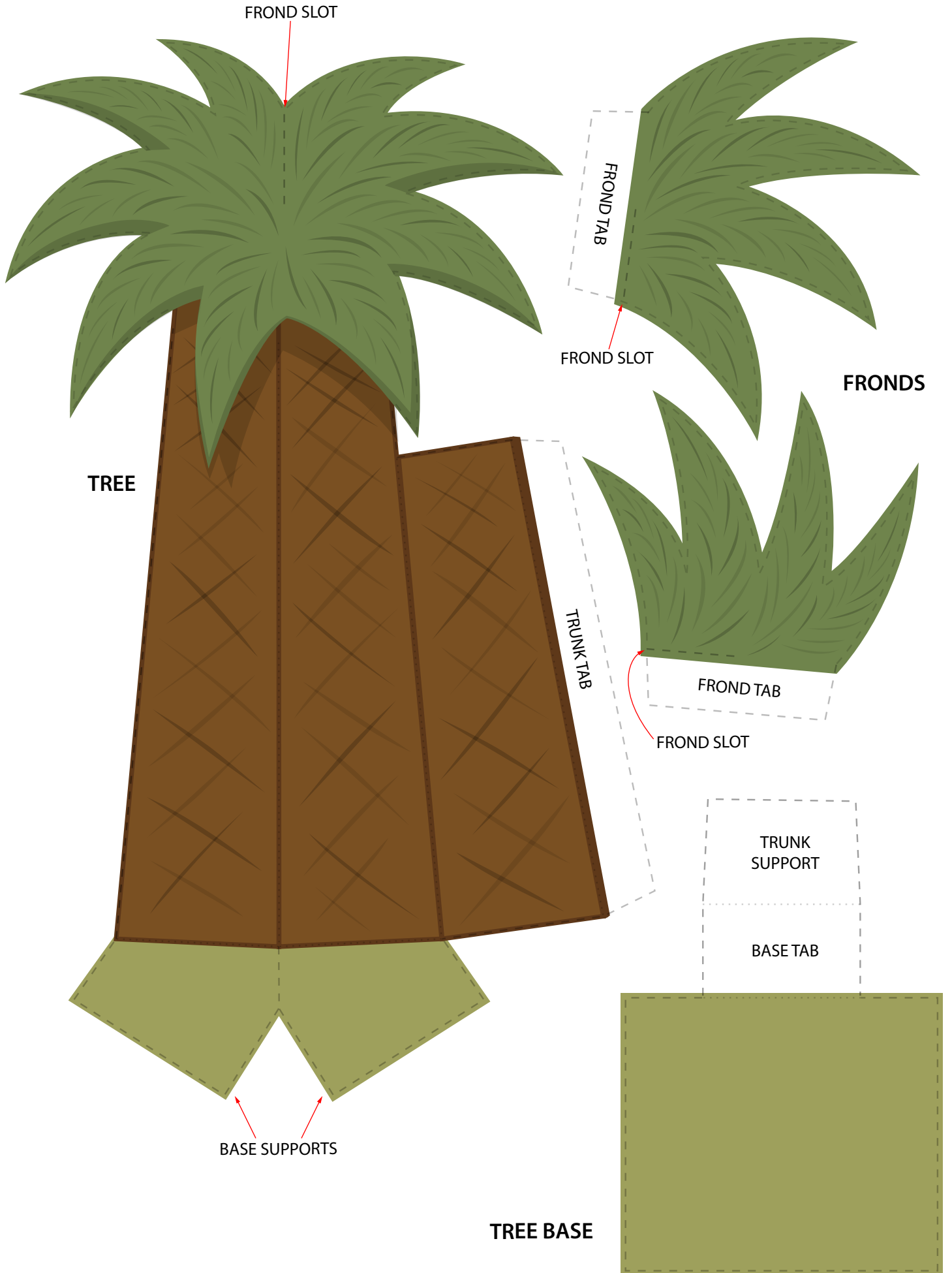

**STEP 1:** Print the sheets onto card stock. If scaling down the prints to better suit your printer's capabilities, be sure to scale down all the pages by the same amount (eg. 95%).

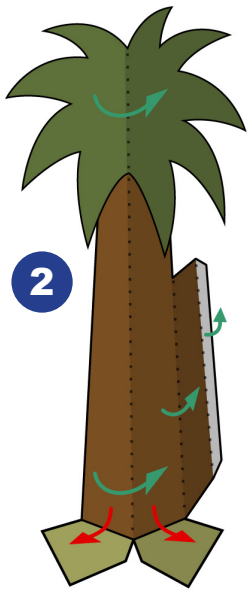

**STEP 2:** Cut out and fold the **Tree** sections.

**STEP 3:** Apply glue to the **Base Tab** and press it down firmly to the **Tree Base**.

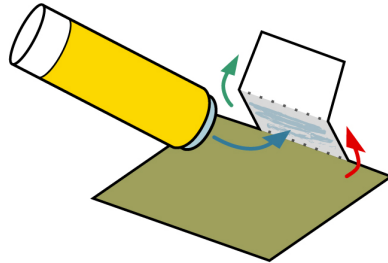

3

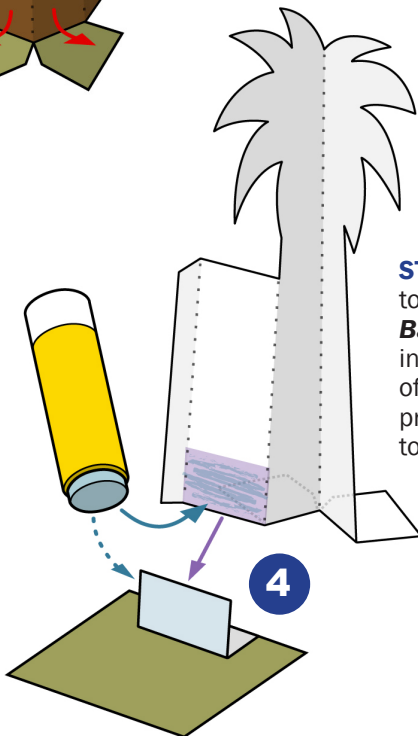
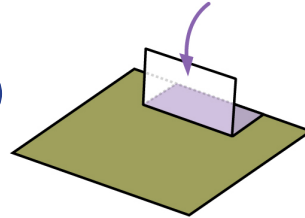

**STEP 4:** Apply glue to the back of the **Base Support** and inside back section of **Tree trunk** and press sections together.

4

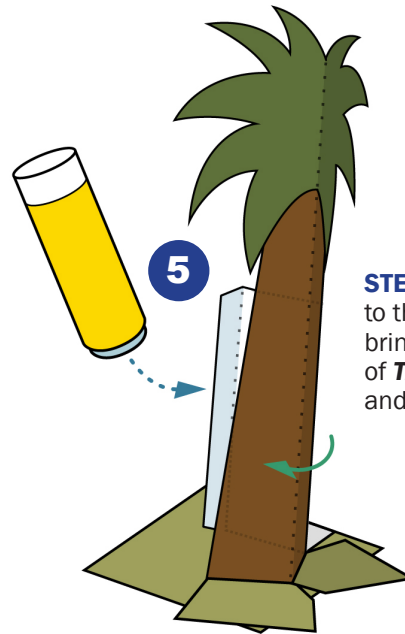

5

**STEP 5:** Apply glue to the **Trunk Tab** and bring opposite side of **Tree Trunk** around and press together.

**STEP 6:** Apply glue to undersides of the **Base Supports** and press firmly onto the **Tree Base**, aligning the corners.

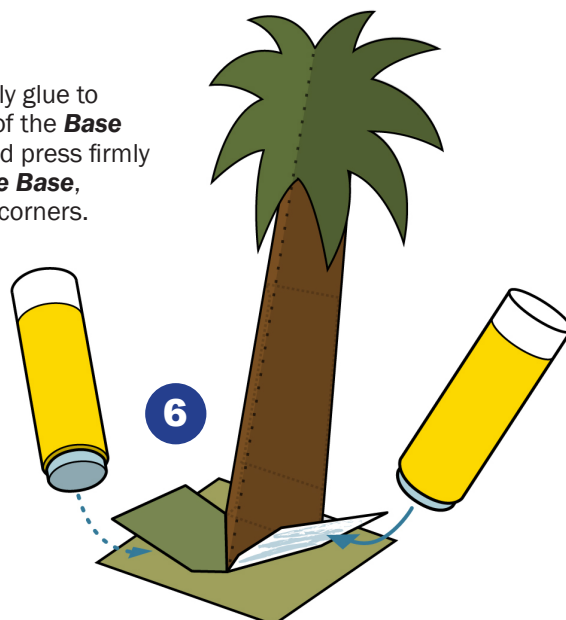

6

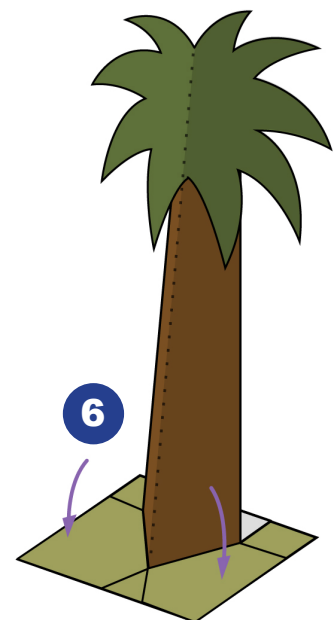

6

